

40
W.O.
1183



[All Rights Reserved.]

m

HANDBOOK

OF THE

6-INCH B.L. GUNS, MARKS VII & VII'

(LAND SERVICE)



1911.

(From War Pamph. v. 121)



*3555.04
W19.*

LONDON:

PUBLISHED BY HIS MAJESTY'S STATIONERY OFFICE.

To be purchased, either directly or through any Bookseller, from
WYMAN AND SONS, LTD., FETTER LANE, E.C.; or
OLIVER AND BOYD, TWEEDDALE COURT, EDENBURGH; or
E. PONSONBY, LTD., 116, GRAFTON STREET, DUBLIN.

PRINTED BY
MACKIE AND CO. LTD., WARRINGTON AND LONDON.

Price Ninepence.

HANDBOOK

OF THE

6-INCH B.L. GUNS, MARKS VII & VII^V

(LAND SERVICE)



1911.



LONDON :
PUBLISHED BY HIS MAJESTY'S STATIONERY OFFICE.

To be purchased, either directly or through any Bookseller, from
WYMAN AND SONS, LTD., FETTER LANE, E.C. ; or
OLIVER AND BOYD, TWEEDDALE COURT, EDINBURGH ; or
E. PONSONBY, LTD., 116, GRAFTON STREET, DUBLIN.

PRINTED BY
MACKIE AND CO. LTD., WARRINGTON AND LONDON.

Price Ninepence.

CONTENTS.

		PAGE.
Ordnance, B.L., 6-inch, Marks VII and VII ^v :—		
Particulars		1
Gun body, Mark VII		2
Gun body, Mark VII ^v		3
Breech mechanism		3
Firing mechanism		7
Action of firing mechanism		8
Removing and replacing breech mechanism		8
Separate demandable stores :—		
Bit, vent		10
Borer, tube chamber		10
Box, obturator, steep coned		10
Box, spare parts		10
Extractor, tube, special, box, slide A		10
Press, obturator, steep coned		11
Gauge, thickness, obturator, steep coned		11
Tommy, presses, obturator, steep coned		11
Tool, withdrawing, anti-friction washer		11
Gauge, striker, eccentricity, small		11
Gauge, striker, protrusion		11
Rimer, vent, axial, short		11
Wrenches, breech mechanism		11
Side arms, &c.		12
Care and Preservation of Ordnance and Aiming Rifles		14
Rifle, aiming, 1-inch Elswick " B "		14
Guns, sub-calibre, Q.F., 3-Pr. :—		
Description		17
Instructions for assembling and removing		19
Carriage, garrison, B.L. 6-inch, C.P., Mark II :—		
Description		20
Sights and Sighting Gear		25
Instructions for changing cams		26
Electric firing gear		27
Range Dials		28
Shield		29
Pedestal		29
Ring, levelling		29
Holdfast		30
Arc, traversing		30
Cover, carriage		30
Spanners and special implements		30
Particulars of Mountings for lifting purposes		31
Apparatus, testing gunlayer		32
Apparatus, withdrawing gun from cradle		32
Bar, testing sighting gear		32

Holders, sight cam, &c.	32
Box and Tray spare parts, &c.	33
Care and Preservation of Carriage, Sights, &c.	33
Telescopes	35
Ammunition :—	
Cartridges	39
Projectiles	41
Augmenting strips	44
Fuzes	44
Tubes	48
Drill	52

Plates.

Guns	I
Breech mechanism	II
Firing mechanism	III
Rifle, aiming	IV
Gun, sub-calibre	V
Carriage	VI and VII
Buffer, hydraulic and running out springs	VIII and IX
Sight, rocking bar	X
Cartridges	XI and XII
Projectiles	XIII to XVII
Fuzes	XVIII to XX
Tubes	XXI to XXIII

NOTE.—This book has been corrected up to March, 1911. Any alterations which may be suggested should be forwarded to Chief Inspector, Royal Arsenal, Woolwich.

ORDNANCE, B. L. 6 INCH, WIRE, MARK VII.

SCALE = $\frac{1}{32}$.

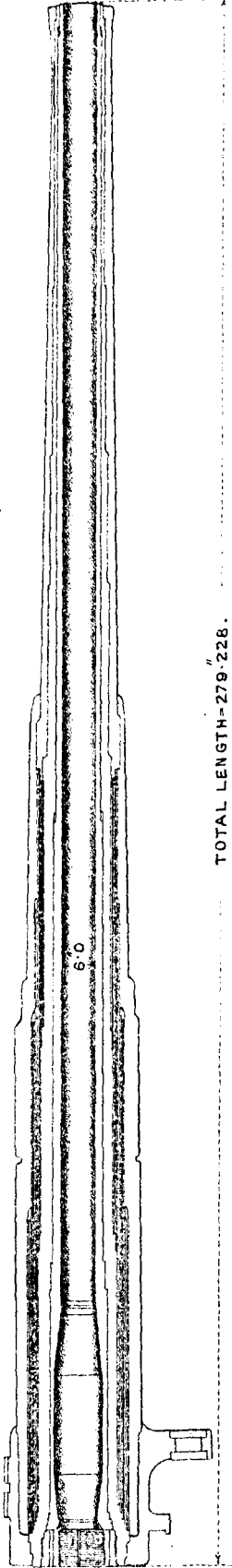

TOTAL LENGTH = 279.228.

ORDNANCE, B. L. 6 INCH, WIRE, MARK VII.

SCALE = $\frac{1}{32}$.

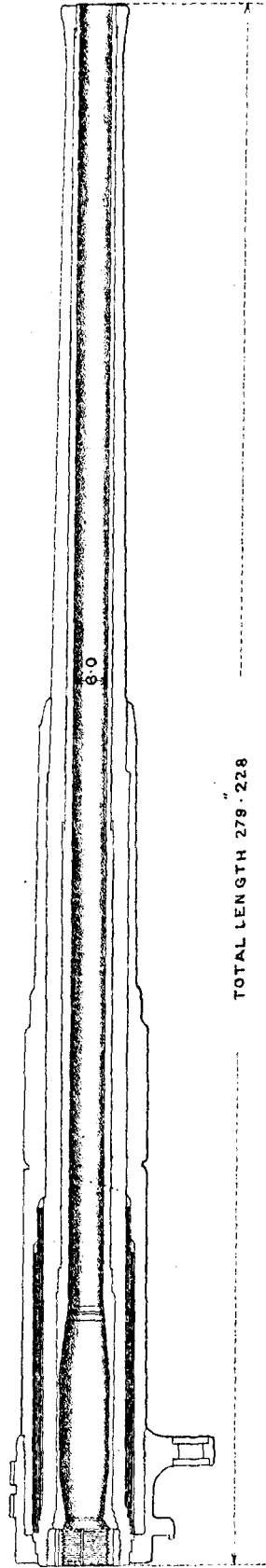

TOTAL LENGTH 279.228

Handbook of the 6-inch B.L. Guns, Marks VII and VII^v, L.S., 1911.

AMENDMENT.

40

W. O.

1653

Page 10—*insert* at bottom :—

“EXTRACTOR, TUBE, HAND, BOX SLIDE, ‘A,’ MARK I.

The hand tube extractor is for use with guns having Marks I** and II boxes slide ‘A’ with strengthened extractor, when the tube is so tightly jammed in the vent that the extractor in the box slide fails to remove it.

† The extractor consists of a steel lever shaped so as to admit of the insertion of one end under the extractor lever in the box slide. On exerting pressure on the outer end of the hand extractor, the tube will be forced out.”

PUBLIC LIBRARY OF VICTORIA

HANDBOOK

OF THE

6-INCH B.L. GUNS, MARKS VII & VII^V.

LAND SERVICE.

GUN.

(Plate I.)

PUBLIC LIBRARY OF VICTORIA

Material	steel (wire construction).	
Length, total	279·228 inches.	
Weight of gun {	with breech fittings (including shot guide)	7 tons, 10 cwt. 2 qtrs. 19 lb.
	without breech fittings	7 tons, 7 cwt. 2 qtrs.
Position of centre of gravity {	with breech fittings	91·3 inches from face of breech.
	without ,, ,,	93·2 inches from face of breech.
Bore {	calibre	6 inches.
	length	269·5 inches=44·9 calibres.
	capacity including chamber and grooves	8605 cubic inches.
Chamber {	length { original form of chamber ...	32·3 inches.
	modified form of chamber	32·658 inches.
	diameter { largest	8·5 inches.
	smallest	6·715 inches.
capacity	1715 cubic inches.	
system	polygrooved, modified plain section.	
Rifling {	length { guns with original form of chamber	234·783 inches.
	guns with modified form of chamber	233·602 inches.
twist	Marks I and III rifling	straight from breech end of rifling to 211·06 inches from the muzzle, then increasing from 0 to 1 turn in 30 calibres at muzzle.

Rifling	}	twist	Mark II* rifling	straight from breech end of rifling to 198·8 inches from the muzzle, then increasing from 0 to 1 turn in 30 calibres at muzzle.
		grooves	}	number	{ Marks I and II* rifling	24.
					{ Mark III rifling	36.
				depth
width	{	Marks I and II* rifling	...	·6 inch.		
		Mark III rifling	...	·38 inch.		
Means of rotation	Driving band.	
Firing mechanism	Electric and percussion.	
System of obturation	Pad (steep coned).	

GUN BODY, MARK VII.

(Plate I.)

The gun body is of steel, and consists of tubes, a series of layers of steel wire, jacket, breech bush, and breech ring. The "A" tube is lined with an inner "A" tube extending from the seat of obturator to the muzzle, secured longitudinally by corresponding shoulders (with cannellured rings along the chase when repaired with new inner "A" tube), and the breech bush which is screwed into the "A" tube at the rear; the bush is also prepared for the reception of the breech screw. Over the chamber and a portion of the bore are wound successive layers of steel wire the ends of which are secured to steel rings. The "B" tube is shrunk round the "A" tube immediately in front of the wire, extending to the muzzle. The jacket is fitted and shrunk round the exterior of the wire, and a portion of the "B" tube, respectively, and is secured longitudinally by means of corresponding shoulders on the "B" tube, and the breech ring which is fitted over the rear end of the "A" tube and screwed to the jacket. The breech ring is prepared for the reception of the breech mechanism, and is provided with projections on the upper side for the attachment of naval service fittings for dismounting purposes. Projecting lugs are formed on the underside of the breech ring for the attachment of the gun to the hydraulic buffer, and to running out springs of the carriage. The exterior of the jacket is furnished with two longitudinal projections on the upper and lower side respectively, forming guides for the gun when in the cradle.

The central portion of the chamber is cylindrical, reduced in diameter with a curved slope in front, and coned at the rear, but in

ORDNANCE, B. L. 6-INCH, WIRE, MARK VII & VII^V

GENERAL ARRANGEMENT OF BREECH MECHANISM

SCALE = 1/6

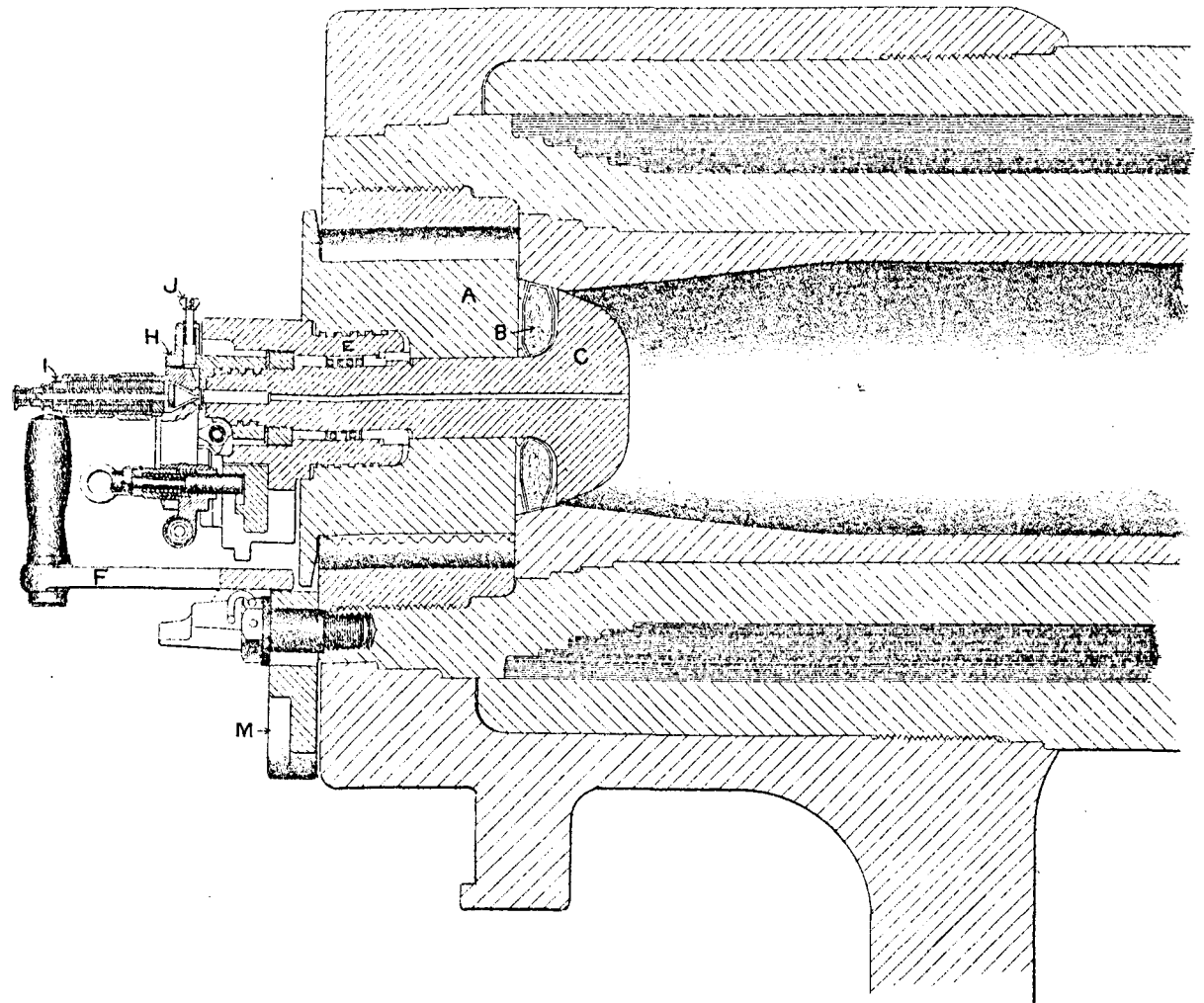
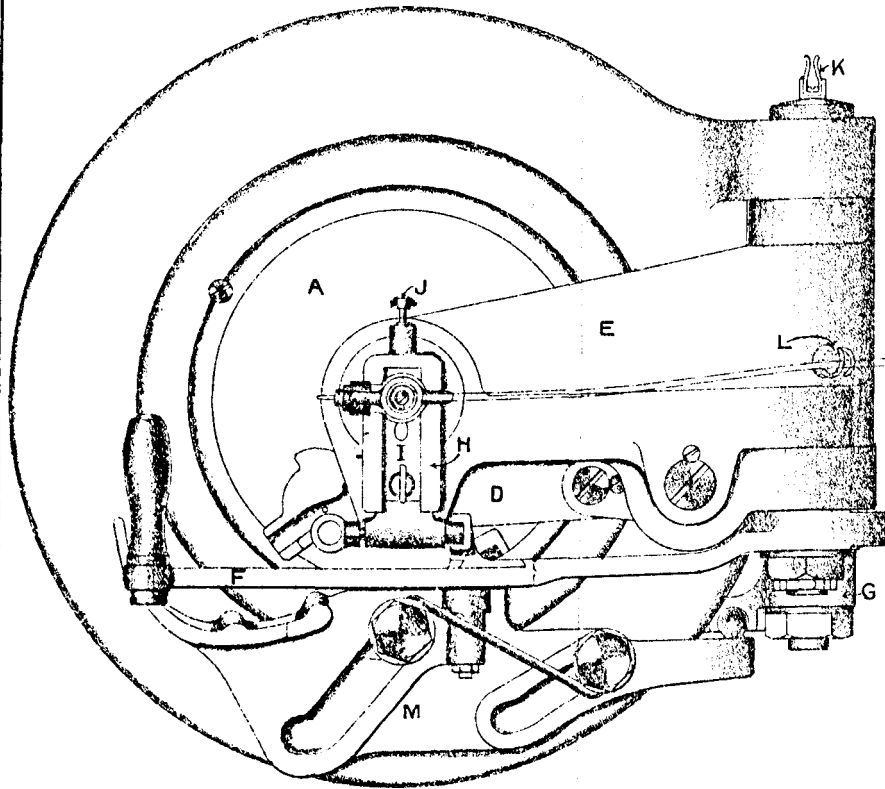

- | | |
|----------------------------|-----------------------------|
| A. BREECH SCREW. | G. LEVER SHOT GUIDE. |
| B. OBTURATOR. | H. BOX SLIDE. |
| C. AXIAL VENT. | I. LOCK E & P, "F". |
| D. LINK. | J. TUBE RETAINER. |
| E. CARRIER. | K. CLIP SUPPORTING LANYARD. |
| F. LEVER BREECH MECHANISM. | L. HOOK SUPPORTING CABLE. |
| | M. SHOT GUIDE. |

latest manufacture and guns repaired with new inner "A" tubes the front of the chamber is also coned.

A plane for clinometer is prepared on the upper surface of the breech ring at the rear.

Axis lines .05-inch deep are cut on the horizontal axis at the breech and muzzle ends on the right side. Fine horizontal and vertical axis lines are also cut on the breech and muzzle faces.

The actual weight of the gun is engraved on the top of the jacket in front of the breech ring, and the Royal monogram on the chase.

The nature, mark, registered number, manufacturers' initials, and year of manufacture are engraved on the upper portion of the breech face.

GUN BODY, MARK VII^V.

(Plate I.)

The gun body differs from Mark VII in construction as follows:—The "A" tube is of greater thickness, and the layers of steel wire extend only over the chamber and the rear portion of the bore. The jacket is fitted and shrunk over the exterior of the wire, and portions of the "A" tube, and is secured longitudinally by corresponding shoulders on the "A" tube, and the breech ring which is fitted over the rear end of the "A" tube and screwed to the jacket.

BREECH MECHANISM.

(Plate II.)

The guns are fitted with a "Single Motion Breech Mechanism." The mechanism is so arranged that by one pull on a lever the breech screw is automatically unlocked and swung into the loading position. After loading, one thrust on the same lever inserts the breech screw and turns it to the locked position. At the same time the striker of the lock is retained in a position of safety, until the breech screw is securely locked and the breech mechanism lever quite home.

The names of the principal parts of the breech mechanism are shown on Plate II.

DESCRIPTION OF BREECH MECHANISM.

Breech Screw.—The breech is closed by a parallel screw of the Welin type, which differs from the ordinary interrupted screw in having a larger amount of thread in proportion to its length (in this case there are four sections of screw threads and two sections plain) by arranging segments at varying diameters, the breech opening of the gun being prepared in a corresponding manner. The interruptions in the gun are arranged to accommodate the segments of the screw of largest diameter; thus, when the screw is unlocked these segments pass into the interruptions and the segments next smaller in diameter unlock into the spaces left vacant by the larger ones.

The interior of the screw is recessed to fit over a circular projection (or pintle) on the front of the carrier, to which it is connected by interrupted screw threads, also for the reception of the axial vent.

A projecting flange is formed at the rear end of the screw and upon the rear face is a stud to engage the outer end of the "link breech screw."

A hard steel piece, provided with a recess, to engage the "catch retaining breech screw," is fitted in the rear face of the breech screw on the right side.

Obturator.—Obturation is obtained by means of a mushroom headed axial vent of steel, passing through the centre of the breech screw and carrier, with a pad and a pair of metal discs. The inner face of the breech screw is flat, and between it and the head of the vent, the pad and discs are arranged. The pad (except those of future manufacture for Mark II obturators) is made of asbestos, worked up with mutton suet to a proper consistency, and enclosed in a strong canvas cover; it is reduced to shape, and pressed in a hydraulic machine. The pad is enclosed between two protecting discs.

Mark I obturators (originally issued with the guns), consist of a pad with front and rear protecting discs of tin or aluminium cadmium. The outer circumference of front and rear discs are protected by a steel ring, and the rear disc is also bushed with a ring of manganese bronze.

Mark II obturators differ from Mark I above, in the pad being heavier and of slightly different shape. The rear protecting disc is of tin, bushed with a ring of manganese bronze, and having a steel ring round the circumference. The front protecting disc is of copper, shaped to fit the front of the pad, and is provided round the outer edge with a split steel ring which is arranged to suit the seating for obturator in the gun.

In future manufacture pads for Mark II obturators will consist of asbestos mixed with rape oil instead of with mutton suet as hitherto, and will be marked in black paint with the words "rape oil" on the canvas cover.

The obturator is of the steep coned type.

The angle of the cone seating in the gun for the obturator, and of the obturator is about 26°.

The discs are stamped with the words "Front" and "Rear" respectively, and the pads have the words "Front" stencilled on the side which corresponds with the front disc, and "Rear" on that which corresponds with the rear disc, in order that they may be correctly assembled on the vent.

If correctly assembled the whole should fit together compactly.

Action.—When the breech screw is pushed into the gun, the obturator enters the chamber with perfect ease; on turning the breech screw, the obturating pad is pressed home into the coned seat in the gun by the travel of the screw. The bore is thus perfectly closed by a species of buffer in contact all round the circumference, while the mushroom head of the vent receives the force of the gas on discharge. On firing the gun the pressure acts on the mushroom head of the vent and compresses the pad against

the breech screw, causing it to expand laterally; from symmetry of form and position, this expansion must be radial to the axis and equal in every direction, and is sufficient to prevent the escape of the gas. On the pressure being removed, elasticity comes into play, and the obturator can be withdrawn from the cone as soon as the screw is unlocked.

Full instructions regarding the fitting, testing, adjusting, and treatment of pad obturators are contained in "Regulations for Magazines and Care of War Matériel."

Axial Vent.—The axial vent consists of a mushroom headed steel spindle with a fire channel through its longer axis enlarged at the rear end to form a tube chamber; externally it is provided with a feather to engage in a featherway in the sleeve; screw threads to engage those of the vent nut, and interrupted thrust collars for the attachment of the slide box. The sleeve, spiral spring, washer, nut, and No. 1 anti-friction washer are placed upon the vent in the order named.

The sleeve is a hollow cylinder of steel provided internally with a featherway to engage the feather on the axial vent, and externally with a feather to engage in a featherway in the interior of the carrier, and so prevent the axial vent revolving and the slide box from becoming disconnected.

The No. 1 anti-friction washer is placed over the outer end of the vent to the rear of the vent nut so as to prevent jamming between the latter and the inner face of the slide box in the gun.

Link, breech screw.—The link is in two parts designated respectively Parts I and II. Part I works on an axis pin in the interior of the carrier, and has four teeth formed on one side of its circumference which engage with corresponding teeth in the link pinion by means of which it is actuated. Projecting lugs with hinge pin on the opposite side form a hinge joint by which it is connected to Part II. The outer end of Part II engages the stud on the rear face of the breech screw, and has a cam groove formed on its rear face for the reception of the inner end of the link guide bolt of the electric and percussion lock.

Carrier.—The carrier body is of manganese bronze and is hinged to the right side of the breech ring of the gun by means of a steel hinge bolt. The hinge bolt is furnished with two steel feathers which engage with a corresponding featherway in the carrier so as to partially revolve with the latter in opening and closing the breech. The lower end of the hinge bolt is prepared with two feathers for the reception of the shot guide lever, and furnished with nut and keep pin. A gunmetal bearing washer is provided for the under side of the carrier hinge joint.

The carrier extends across the breech opening of the gun, having upon its front face a large cylindrical projection (or pintle) which forms a pivot for the breech screw. The projection (or pintle) is provided on its exterior with interrupted screw threads corresponding with those in the interior of the breech screw, and is recessed to receive the axial vent with its fittings.

A steel stud is screwed into the lower side of the carrier, near the hinge joint, and forms a pivot for the breech mechanism lever. The stud is secured from turning when in position by means of a check screw.

Breech mechanism lever.—The breech mechanism lever is of steel, having a boss near one end prepared with three feathers on the exterior for the reception of the link pinion. The lever is pivoted through the centre of the boss to the under side of the carrier by means of a stud, and is secured by a castellated nut and keep pin. A projecting lug on the boss engages the carrier after the breech screw is unlocked and serves to turn the carrier into the loading position. The opposite end of the lever is provided with a gun-metal handle. Near the centre of the lever on the upper side is fitted a safety bracket having a cam groove which engages the lever guide bolt of the electric and percussion lock, and serves to withdraw the lock from, or force it into, the firing position during the first or last movements of the lever, respectively, in opening or closing the breech. A recess is formed on the under side of the lever for the reception of the upper end of the retaining catch in the shot guide.

Link pinion.—The link pinion is of manganese bronze, and is provided with teeth which engage with corresponding teeth in the "link, breech screw." A recess is formed in the under side of the pinion which engages a stud in the breech mechanism lever when in position, and serves to ensure the pinion being correctly assembled on the lever.

Catch Retaining Breech Screw.—Is a hollow steel cylinder placed within the recess in the front of the carrier and kept pressed forward by a spiral spring inside it. Externally, it is provided with a feather, which by gearing into a featherway in the carrier prevent its turning, and also with two projections, one to engage in the recess in the flange of the breech screw, and the other to effect the withdrawal of the former by coming into contact with the face of the breech of gun when closing the breech.

Hook supporting Cable.—The hook is of bullmetal (latest manufacture steel nickel-plated), and is fitted together with a spring washer to the rear face of the carrier near the right side by a securing screw.

The hook consists of a disc upon which two projections are formed and bent in opposite directions to form a double hook, for the purpose of receiving and supporting the electric cable between the electric lock and the contact on the gun. When placing the cable in position the hooks must be horizontal, they are afterwards turned to the vertical position.

Shot Guide.—A bronze shot guide, to facilitate loading, is attached to the gun at the breech by two guide screws, which pass through corresponding cam grooves in the guide, and serve to support it laterally. The guide screws are secured from turning when in position by means of a locking wire. The guide is actuated by means of a lever, which is fitted to the lower end of the carrier hinge bolt, and engages with a ball pin on the guide when the breech is opened, thus forcing the guide into the loading position by means of the inclined planes of the cam grooves engaging with the guide screws in the gun.

A catch with spiral spring is fitted to the upper side of the shot guide for retaining the breech mechanism lever in the closed position.

FIRING MECHANISM - DETAILS.
 BOX SLIDE "A".
 LOCK ELECTRIC & PERCUSSION "F".

SCALE = 1/2

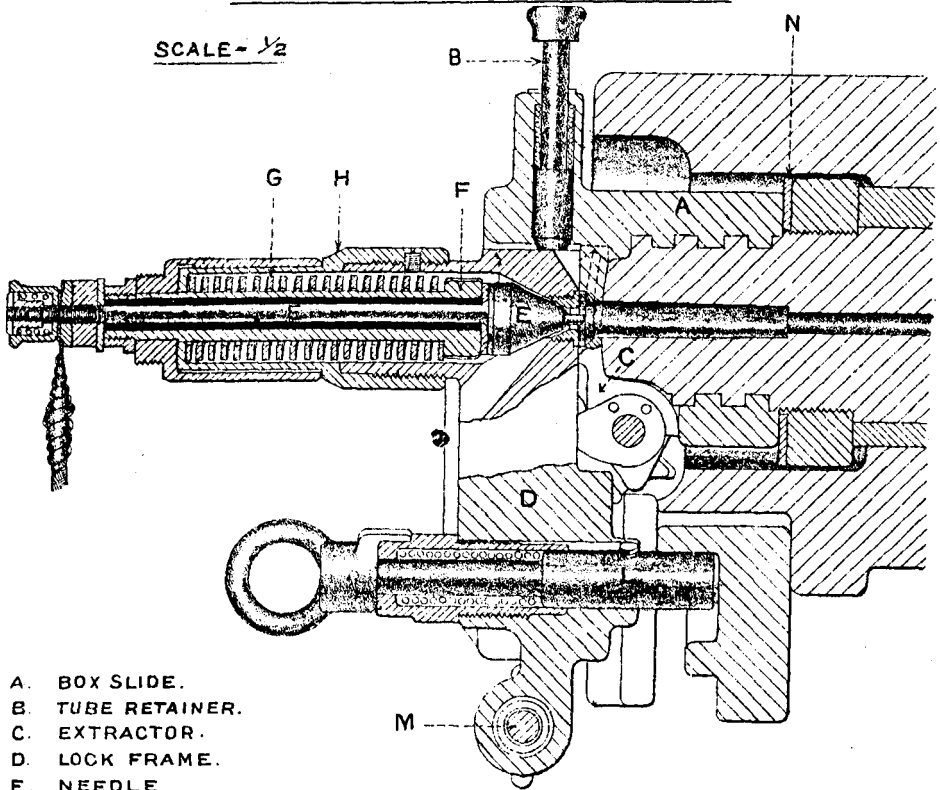

- A. BOX SLIDE.
- B. TUBE RETAINER.
- C. EXTRACTOR.
- D. LOCK FRAME.
- E. NEEDLE
- F. SHEATH.
- G. MAIN SPRING.

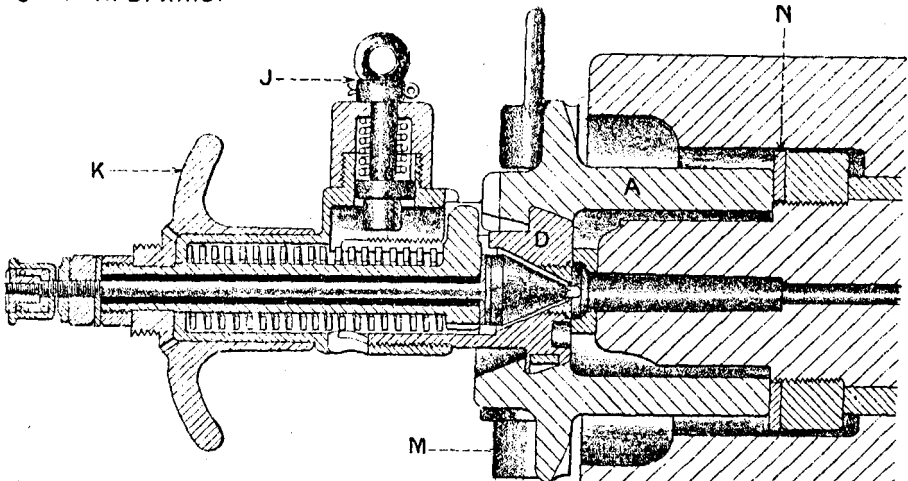

- H. CASE.
- J. TRIGGER.
- K. COCKING HANDLE.
- L. GUIDE BOLT, LINK.
- M. " " , B.M. LEVER.
- N. ANTI FRICTION WASHER N°1

FIRING MECHANISM.

(Plate III.)

The firing mechanism is designed for percussion firing, and for electric firing with wireless tubes, and is so arranged that the gun cannot be fired before the breech is fully closed.

The slide box "A," in which the percussion and electric lock slides, is secured to the outer end of the axial vent by interrupted thrust collars; the lock being automatically moved over or away from the vent by the closing or opening of the breech.

Upon the left side of the slide box is fitted a safety slide which retains the needle of the lock clear of the vent sealing tube in the vent except when the breech is fully closed.

An extractor in two parts is mounted upon an axis pin between the sides of the slide box to automatically extract the fired V.S. tube from the vent. The extractor is actuated by an actuating plate and toe piece fitted to the front of the lock frame, and a small stop pin with spiral spring is fitted in the slide box in such a manner as to retain the extractor in either the closed or open positions.

A "bolt retaining tube" is fitted in the slide box to prevent the tube setting back in closing the breech.

Box, SLIDE, "A."

The following are the principal parts of the slide box:—

Body with safety slide with 3 fixing screws.

Extractor lever with actuating collar, axis pin, washer, and keep pin.

Tube retainer bolt with cap, keep pin, copper washer and spiral spring.

Stop pin with spiral spring.

Lock, ELECTRIC AND PERCUSSION, "F."

The following are the principal parts of the lock:—

Lock frame with plate actuating extractor and 2 screwed rivets, tripping piece and 2 screwed rivets, cylindrical toe piece, toe piece retaining plate with fixing screw, firing hole bush, link guide bolt bush, and cam groove bush with set screw.

Needle with insulator and keep screw, Mk. II firing pin, retaining and locking nuts, sleeve, spring, and securing nut for use with expendable cable.

Sheath with nut.

Main spring.

Case with fixing screw and cap.

Trigger in 2 parts with keep pin and spiral spring.

Cocking handle.

Link guide bolt in 2 parts with keep pin and spiral spring.

Breech mechanism lever guide bolt in 2 parts with keep pin and spiral spring.

Description.—The lock consists of a steel frame provided on the front face with actuating plate, tripping piece and toe piece for actuating the extractor in the slide box. The lower portion of the

frame is furnished with two guide bolts, the upper one designated as link guide bolt, engaging with the cam groove of the link in the carrier, and the lower one as breech mechanism lever guide bolt, engaging with the safety bracket on the breech mechanism lever. A case containing an insulated steel needle, sheath with nut, and main spring, is secured to the rear face of the lock frame. The inner end of the needle is prepared with a firing pin which projects through a firing hole bush in the front face of the lock frame and engages the head of the vent sealing tube in the gun. The outer end of the needle is furnished with a nut and sleeve with spring and securing nut for the attachment of the expendable cable for electric firing. A cocking handle is provided on the rear end of the sheath by means of which the needle is pulled into the cocked position, and retained by the trigger which engages with a projection on the sheath. The trigger is pulled by means of a firing lanyard from the left side of the gun.

ACTION OF FIRING MECHANISM.

In closing the breech the electric and percussion lock "F" is forced in an upward direction by means of the cam groove of the link in the carrier so as to mask the vent sealing tube in the gun, and is pushed into a central position over the head of the tube by the last movement of the breech mechanism lever.

In opening the breech the first movement of the breech mechanism lever forces the lock downwards in the slide box, causing the projection on the sheath to engage the safety slide on the slide box thus withdrawing the needle to the rear, clear of the vent sealing tube in the gun. The safety bracket on the breech mechanism lever is then clear of the lever guide bolt, and on continuing the motion of the breech mechanism lever the lock is forced downward by the cam groove of the link until the vent sealing tube in the gun is unmasked.

REMOVING AND REPLACING BREECH MECHANISM.

Care must be taken not to indent or damage the components, and a hammer should never be used unless with a piece of wood or soft metal to transmit the blow.

The fittings should be examined frequently as to their condition in respect to wear, in order that, if necessary, special examination may be called for. (See Notes, page 9.)

REMOVAL OF PARTS.

This is done with the breech fully open; except when removing the carrier which must be taken off in the closed position, so that the feather on its hinge bolt may coincide with the featherway in the upper bearing of the breech ring. The parts may be removed in the following order:—

Lock.—Remove the electric cable "A," draw back the link guide bolt and move the lock downwards till clear of the slide box.

The lock may be removed with the breech closed, thus:—Draw back the link guide bolt until the lug on its head is clear of the

bush, unscrew the latter and remove the bolt with spring; then move the lock downwards till clear of the slide box.

Hook, supporting Cable.—Unscrew the securing screw and the hook is released.

Slide Box.—Disengage the extractor from the recess in the end of the vent, and turn the lower end of the slide box a quarter circle to the right and withdraw it from the recess.

Axial Vent and Obturator.—Remove the anti-friction washer, nut, washer and spring, then take out the vent and obturator from the front of the breech screw.

Breech screw.—Disconnect Parts I and II of the link by removing the check screw and hinge pin, press in the catch retaining breech screw clear of the recess in the screw and turn the latter until the threads in its interior are clear of those on the carrier, from which the screw may then be removed. The sleeve of the axial vent will then be withdrawn from the carrier.

Link.—Part II is taken off with the breech screw, but may be removed independently if desired.

Part I.—Remove check and axis screws, and take off from the under side of the carrier.

Lever, breech mechanism, link and pinion.—Remove the nut and keep pin from the axis pin, and take off together.

Lever, shot guide.—Remove the keep pin and nut from the bottom of the carrier hinge bolt, and take off.

Carrier.—Swing the carrier to the closed position, force the hinge bolt upwards, and remove it; the carrier may then be lifted off.

Shot guide.—Withdraw the locking wire from the guide screws, remove the guide screws, and withdraw the shot guide.

REPLACING THE PARTS.

This is the converse of the foregoing; however, the following exceptions may be mentioned:—

Lock.—It will be an advantage to cock the lock before placing it in the slide box.

Link.—It is desirable in replacing Part I, but not absolutely necessary, to have the “lever breech mechanism” in the closed position.

NOTES.—When examining the breech fittings care must be taken to test the concentricity of the striker with the tube in the vent. For this purpose a “gauge, striker, eccentricity” is provided, which is suitable to fit in the tube chamber of the vent; in the head of the gauge is a removable plug, upon which the position of the striker point is indicated when the striker is cocked and released with the gauge in position. If the indent made by the striker point in the gauge is found to be so much eccentric as to be likely to cause missfires with either percussion or electric firing, further examination should be made to ascertain the portion of the mechanism in fault, and steps taken to have it repaired or exchanged.

SEPARATE DEMANDABLE STORES.

BIT, VENT, 23-INCH.

This is of round tempered steel wire, furnished with a spiral bit at one end and hardened at the point, the opposite end is formed into a loop for convenience in handling. It is used for removing irregularities from the vent channel and for cleaning it.

BORER, TUBE CHAMBER, SMALL $\left. \begin{array}{l} \text{square end—} \\ \text{pointed end—} \end{array} \right\}$

The borers are of steel, coned at one end to fit the tube chamber in the axial vent, and are provided with cutting edges for removing obstructions of a hard nature from the tube chamber. The other ends of the borers are provided with a cross handle.

BOX, OBTURATOR, STEEP-CONED, B.L. 6-INCH.

This box is for Marks VII and VII^v guns. It is of bronze; made with a flanged shoulder to take the cover. A steel bolt passes through the box, and a gunmetal nut on the bolt screws down, thus compressing the contents. The box holds an obturator and one adjusting disc.

BOX, SPARE PARTS, B.L. 6-INCH, MARKS III TO VII^v GUNS.

The box consists of a wooden tray, divided into 23 compartments, and it is intended to hold the spare springs and other small spare parts belonging to the guns.

EXTRACTOR, TUBE, SPECIAL, BOX SLIDE, "A."

This instrument generally consists of a sheath or case containing an actuating screw, which screws into the handle and two extracting clips which pivot on an axis pin on the end of the screw; it is for use with guns having the "box slide 'A'," when the tube is so tightly jammed in the vent that the extractor in the box slide fails to remove it.

The sheath is suitably shaped at the clip end to admit of its being inserted in the "box slide, 'A,'" by being made square in section to prevent turning, and in having a flange on two sides to bear on the sides of the box slide.

The revolving cross-handle is attached to the sheath by two rivets; it actuates the screw, moving it in or out, according to the direction the handle is turned, the joint head of the screw and clips being made square in section to prevent their turning in the sheath. The outer ends of the clips fit into corresponding recesses in the box slide; by turning the handle, a guide pin (between the clips) causes them to diverge on passing out of the sheath and over the box slide "A" extractor. On turning the handle in the opposite direction the clips will hook on the jaws of the box slide "A" extractor which, with the tube, will be forced out so that the tube may be removed by hand.

The special tube extractor is not required with Mark I⁰⁰ and II boxes, slide "A."

PRESS, OBTURATOR, STEEP-CONED, B.L. 6-IN.

GAUGE, THICKNESS, OBTURATOR, STEEP-CONED, B.L. 6-IN.

TOMMY, PRESSES, OBTURATOR, STEEP-CONED, B.L. 12-IN. TO 6-IN.
GUNS.

The press and gauge are intended for use in re-forming steep-coned obturators which have become so distorted as to cause difficulty in placing them in position on the vent axial in the gun.

The press consists of a steel body, shaped internally to suit the contour of the obturator, and fitted with a steel cover. The cover is secured by means of a steel bolt with disc spring, washer and crosshandle. The bolt is provided with a square head, by means of which the press can be held in a vice while the crosshandle is revolved when compressing or releasing the obturator. A steel tommy is provided for use with the crosshandle in compressing the obturator. Recesses are formed round the periphery of the press so as to admit of the application of the gauge for testing the thickness of the obturator while under compression.

The gauge is of flat steel plate, and is for use in testing the thickness of the obturators.

TOOL, WITHDRAWING, ANTI-FRICTION WASHER.

The tool, withdrawing, anti-friction washer consists of a piece of steel wire, having a screw thread corresponding with the threaded hole in the washer on one end, and a loop formed at the other end.

GAUGE, STRIKER, ECCENTRICITY, SMALL.

This gauge is of brass, with a removable copper plug, for testing eccentricity of striker in guns using P vent-sealing tubes.

INSTRUCTIONS FOR USE OF GAUGE.

See "Regulations for Magazines and Care of War Matériel."

GAUGE, STRIKER, PROTRUSION No. 3.

The gauge is made of flat steel plate, and is for gauging the protrusion of the firing pin of the needle or striker in electric or percussion locks, for B.L. guns, and the striker in 1-in. Elswick "B," aiming rifle.

INSTRUCTIONS FOR USE OF GAUGE.

See "Drill" and "Regulations for Magazines and Care of War Matériel."

RIMER, VENT, AXIAL, SHORT.

This is of bronze, and is used for clearing the tube chamber of the axial vent.

WRENCHES.

The following wrenches are used with the breech mechanism :—

Wrench Breech Mechanism No. 41.—For large nuts.

„ „ „ *No. 46.*—For vent nuts and all screws.

SIDE ARMS, &c.

Brush, piasaba, 6-in. No. 2, Mark 1.—The brush is used for cleaning the bore of the gun, in conjunction with a sponge cloth or piece of canvas tied on the head.

The head is of elm, having piasaba tufts secured into it by pitch or marine glue.

The stave is of ash, and is secured in the head by a copper rivet. It is fitted with a metal socket-joint, which consists of a metal plug fixed to the intermediate stave, and a metal cylinder fixed to the brush stave; the plug is inserted in the cylinder, and secured in position by a thumb screw fitted to the cylinder.

Total length, with end stave, 25 feet 3 inches.

Brush, piasaba, 6-inch, No. 3.—Mark 1.—This brush differs in length from No. 2, and is intended to supersede the latter.

Mark II—for future manufacture.—The Mark II brush differs from Mark I in being built up, consisting of several parts. Any one of the separate components of the head may be replaced as required.

Total length, with end stave, 27 feet.

Stave, end, No. 14.—For Nos. 2 and 3 piasaba brushes; 13 ft. 6-in. long.

Brush, rammer, and sponge, B.L., 6-in. chamber, Mark I.

This combined brush, rammer, and sponge differs slightly in construction from Mark II, which includes the services given for this Mark, *see below.*

The head is in four parts, which are securely held together by $\frac{3}{8}$ -inch longitudinal bolts.

Brush, rammer, and sponge, B.L., or B.L.C., 6-in. chamber, Mark II.

The head of this combined brush, rammer, and sponge is made of beech in one piece (*a*), and is protected front and rear by copper rings secured by screws, *see sketch I.* The brush portion (*b*) is retained in position on the head against a shoulder (*c*), and angle copper (*d*) and screws; the rest of the head is covered with fleecy hosiery (*e*).

The stave, which is of ash, is secured in the head by a copper rivet (*f*).

Total length of brush and stave combined (over all) 5 feet.

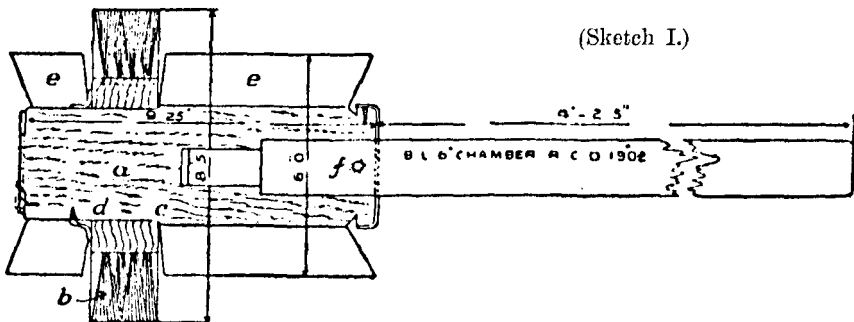

Brush, rammer, and sponge, B.L. or B.L.C. 6-in, chamber Mark III.

The combined brush, rammer, and sponge is to the form and dimensions shown in the accompanying sketch II. The brush portion consists of bristles fixed in brass rings, and secured between two wood collars having a brass lining. The sponge is in two portions, separated by the brush; each portion consists of tufts of wool secured to a brass-lined stock of wood. The rammer is of hard wood, the exposed surface being protected by a copper covering; it is secured, together with a brass sleeve, by copper rivets to the stave. One end of the sleeve is screwed for two securing nuts, which secure the two portions of the sponge, the brush, and the centring ring to the rammer portion.

Total length of combined brush, rammer and sponge, 7 feet 625 inches.

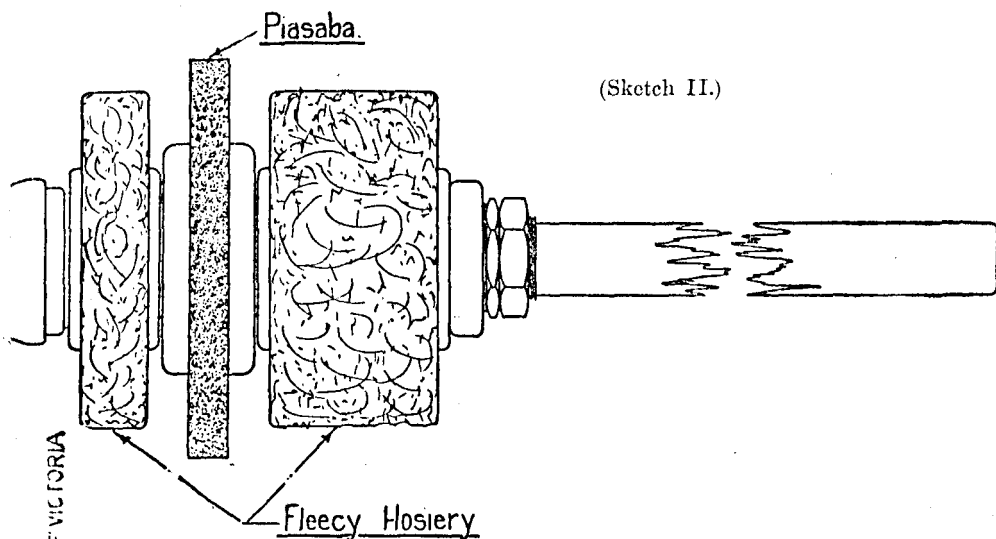

Extractor, drill shell, No. 1.—The extractor consists of an ash stave grooved circumferentially at one end to enable a good grip to be taken when extracting the drill shell. The other end of the stave is furnished with a steel hook for engaging the crossbar of the shell.

Total length 5 feet.

Lanyard, cocking, No. 2.—This lanyard is made of tarred white line with toggle at one end, and at the other end with loops for looping over the lugs of the cocking handle of the lock.

Length 4 feet 6 inches.

A clip for supporting the cocking lanyard, consisting of a steel bracket with spring, is attached by a fixing screw to the upper end of the carrier hinge bolt, the existing lubricating screw in the hinge bolt being removed for this purpose.

Lanyard, firing, No. 7.—This lanyard is made of tarred white line with toggle at one end, and at the other end with hook for hooking on to the trigger of the lock.

Length 8 feet 8 inches.

Hook, withdrawing, guide bolt breech mechanism lever.—This hook consists of an iron rod formed with a hook at one end and bound with lashing. It is intended for hooking into the loop of the breech mechanism lever guide bolt of the electric and percussion lock.

Hook, withdrawing, guide bolt link.—This hook is of steel (later manufacture of bronze) and is fixed to the rear end of the stave of the “brush, rammer, and sponge, B.L. or B.L.C. 6-inch chamber.”

These hooks are made locally and are for use in withdrawing the electric and percussion lock so as to enable the vent sealing tube in the gun to be removed in the event of a missfire, without exposing to danger the numbers serving the gun.

Scraper, B.L. Ordnance, 6-in. to 13.5-inch.—This scraper is intended for use in cleaning the chamber of guns after firing powder charges. Mark I consists of an ash stave with one end formed into a head, on one side of which is riveted a steel scraper, and on the other a brush. The stock of the brush is of beech, to which tufts of bristles are secured by brass wire. Mark II brush differs from Mark I in the scraper, which is of aluminium bronze instead of steel; the latter was found to be too brittle.

Length 6 feet.

Cover, muzzle, No 5.

The cover is of waterproofed canvas, and is secured to the muzzle by a leather strap.

CARE AND PRESERVATION OF ORDNANCE, AND FITTINGS, AND AIMING RIFLES.

(See “*Regulations for Magazines, and Care of War Matériel.*”)

RIFLE, AIMING, 1-INCH, ELSWICK “B,” MARK I.

(Plate IV.)

This apparatus, which is arranged for electric firing only, contains its own firing mechanism (the breech mechanism of the gun is not used with it).

The principal parts of the rifle are as follows:—

- (a) Barrel.
- (b) Breech ring, with set screw and keep pin, safety stop, and extractor.
- (c) Carrier, with hinge pin, and catch retaining breech screw.
- (d) Breech screw, with cam lever, case and set screw.

RIFLE, AIMING, 1 INCH ELSWICK, 'B' MARK I. GENERAL ARRANGEMENT.

SCALE - 1/4

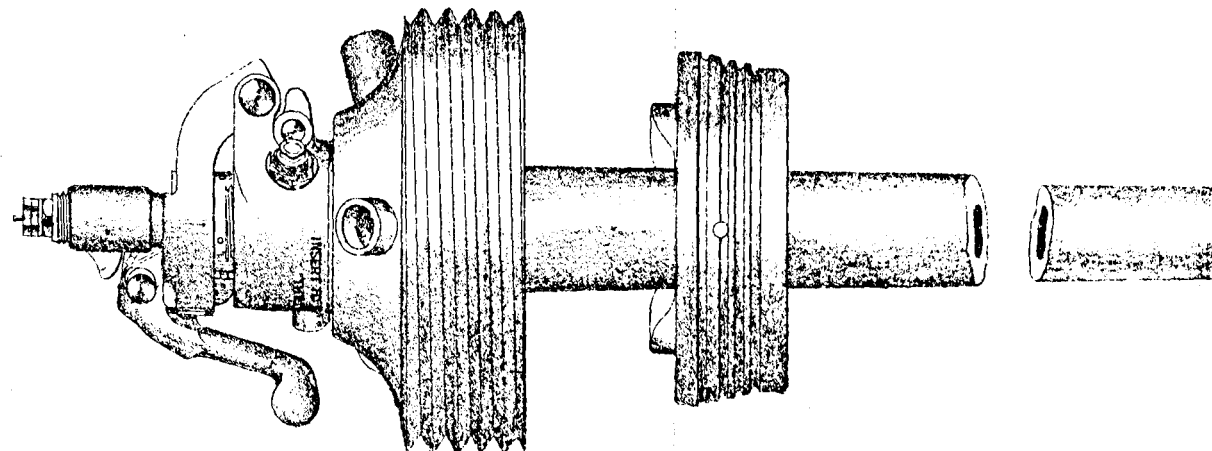
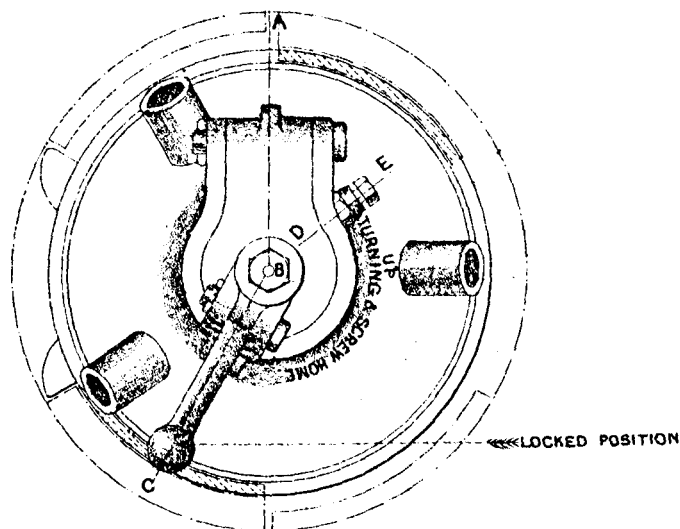

SECTION THRO' D. E.
BREECH RING LOCKED

SECTION THRO' D. E.
BREECH RING UNLOCKED

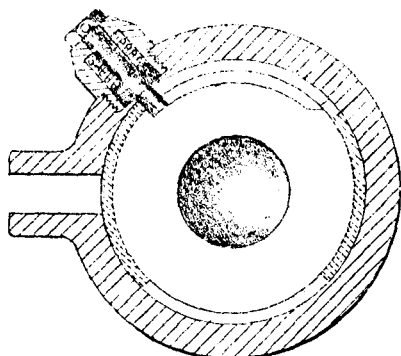
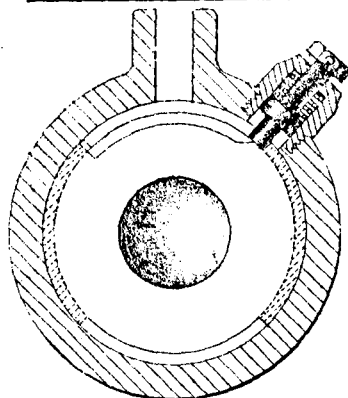

SECTION THRO' D. E.
SHEWING SAFETY BOLT & BREECH RING

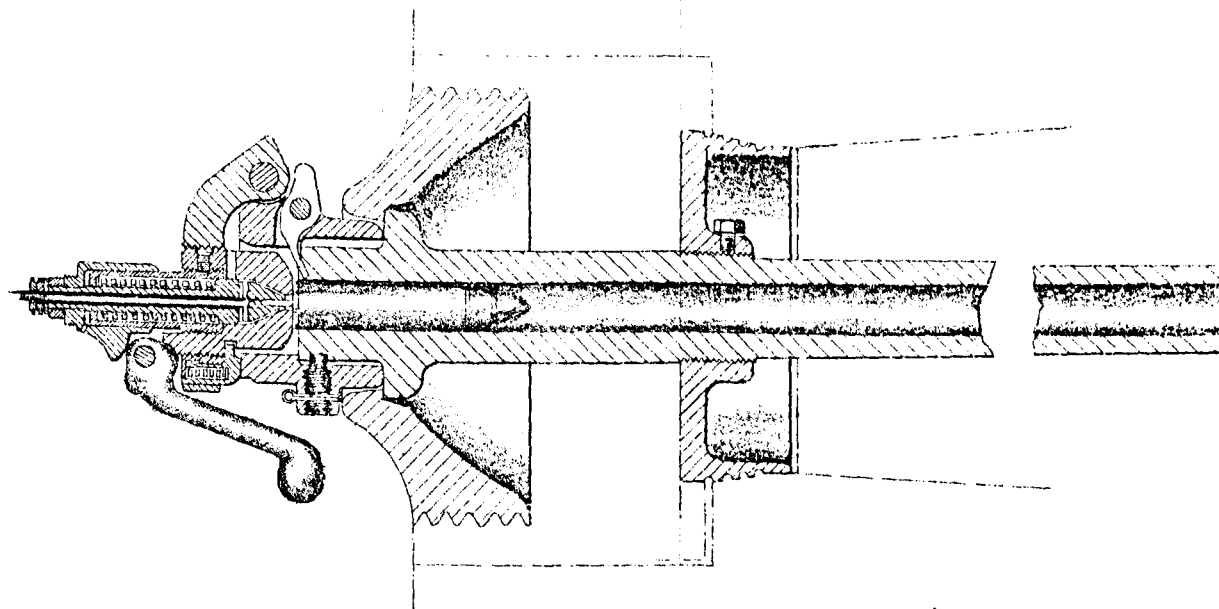
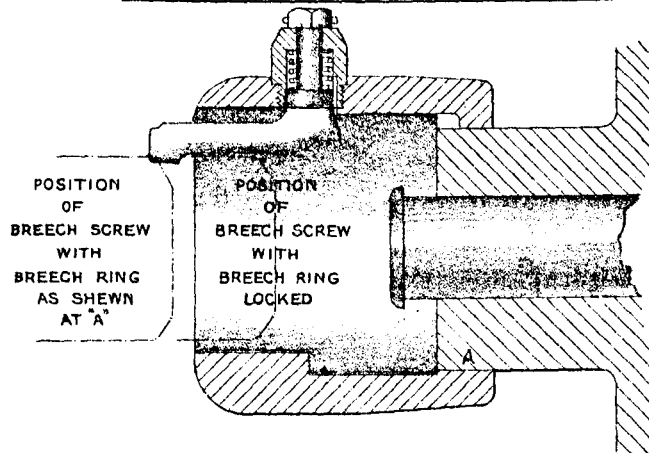

SECTION THRO' A. B. C.

- (e) Sleeve withdrawing striker.
- (f) Striker, consisting of needle, insulating bush, and washers, sheath, and mainspring.
- (g) Frame adjusting, front, with set screw.
- (h) Frame adjusting, rear.^o
 - Mark I with interrupted screw thread, and two handles.
 - Mark II with continuous screw thread, and two handles.
 - Mark III with continuous screw thread and three handles.

DESCRIPTION.

The 1-inch barrel is chambered and rifled on the Henry principle. It is prepared on the exterior at the rear, with interrupted thrust collars for the reception of the breech ring; the latter, which is prepared for the reception of the breech screw, is secured in position on the barrel by means of a set screw and keep pin, and is provided with lugs for the attachment of the breech mechanism of the aiming rifle. It is also fitted with a safety stop to prevent the breech being closed until the breech ring has been locked in position on the barrel. An extractor, which engages with the head of the cartridge in the rifle, is pivoted in the breech ring in such a manner, that when the breech is opened and the carrier swung into the loading position, the cartridge is automatically released.

The breech is closed by a parallel screw having two interruptions corresponding with the interior of the rear portion of the breech ring and is supported, when withdrawn, by a carrier hinged to the breech ring. The screw is attached to the carrier by screw threads on the rear end, which engage with corresponding screw threads in the carrier, and is worked by means of a cam lever.

Fitted to the outer face of the breech screw is a case enclosing a main spring through the centre of which the striker passes. The striker is provided with an insulated needle, one end of which projects through the firing hole of the breech screw, and makes contact with the electric primer of the cartridge. The outer end of the needle is furnished with two nuts.

To prevent the rifle being fired before the screw is locked, and the cam lever lowered, a withdrawing sleeve is fitted over a portion of the spring case, and attached to the rear end of the striker. A projection on one side of the sleeve engages with the cam portion of the lever in such a manner, that the first movement of the lever, in opening the breech, automatically withdraws the striker within the face of the breech screw. The striker is automatically released when the screw is turned into the locked position, and the cam lever folded forward.

METHOD OF FITTING AND USING THE APPARATUS.

The front adjusting frame is screwed over the barrel, until the lines on the front of frame and the right side of barrel coincide, and secured by means of the set screw.

* Either of these marks may be on charge.

The barrel with frame should then be placed in the breech opening of the gun, the part of the frame marked "TOP" being uppermost, the frame fitting in the rear end of the chamber of the gun. The Mark I rear adjusting frame is then placed over the rear end of the barrel, the part marked "TOP" being placed uppermost, pushed into the breech opening as far as it will go, and turned so as to engage with the screw threads of the breech opening. The frame should be jammed tightly into position in the breech of the gun, by means of the tommy, applied in one of the hollow handles on the frame and used as a lever. When correctly assembled the upper handle should be in the "vertical plane."

In the event of the rear adjusting frame screwing beyond the position mentioned above, thin steel discs are provided, to be inserted over the rear end of the barrel, as may be necessary, the frame being temporarily removed for this purpose; and in order to prevent the liability of the frame to unscrew when firing, a filling piece of hard wood is fitted to one of the interruptions in the breech opening of the gun after the rear adjusting frame has been inserted one of the handles may have to be removed before the filling piece can be inserted.

When either Marks II or III rear adjusting frames are supplied, the method of fitting is as follows:—The barrel and front adjusting frame are inserted as before, the Mark II or III frame is placed over the end of the barrel, the part marked "UP" being uppermost, and turned so as to engage with the screw threads of the breech opening. The frame should be screwed tightly home by means of the tommy applied in one of the hollow handles on the frame and used as a lever.

Engraved upon the rear face of the frame is an indicator ring with the words "UP," "START TURNING AND SCREW HOME"; the indicator ring is flush with the rear face of the gun when in position.

The thin steel adjusting discs used with the Mark I frame are not necessary when using either Marks II or III frames.

The breech ring with carrier and breech screw in the open position will then be placed over the rear end of the barrel, and revolved one-fourth of a turn, in such a direction as will admit of the set screw in the breech ring engaging with the recess in the barrel for its reception when the set screw is screwed home. Indicator lines are engraved on the breech ring with instructions to facilitate assembling.

Care must be taken when removing the breech ring from the barrel to see that the breech screw and carrier of the rifle are always in the open position, and the extractor clear of the recess for its reception in the barrel.

Elevation is obtained by means of the carriage sights, and any error in line can be corrected by using the deflection scale.

The following appurtenances and implements are supplied for use with this rifle:—

Extractor Hand.—Is used to remove the empty cartridge case after it has been released by the extractor in opening the breech.

Tommy.—This is a cylindrical steel rod about 17 inches long, tapered at one end, which is inserted in one of the hollow handles of the rear adjusting frame, to give additional leverage in revolving it.

GUN, SUB CALIBRE, Q.F. 3 PR. B.L. 6 INCH, MARKS VII & VII^x GUNS, MARK II.

SCALE = $\frac{1}{8}$

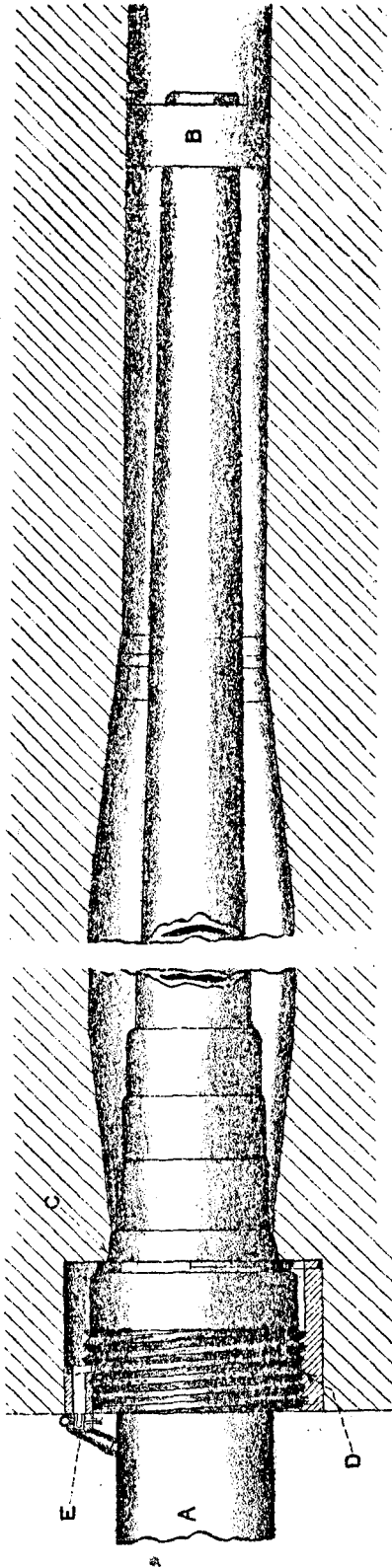

- A SUB-CALIBRE GUN.
- B FRONT ADJUSTING FRAME,
- C RING PRESERVING OBTURATOR SEAT.
- D BLOCK CENTRING.
- E CATCH RETAINING.

Wrench Aiming Rifle, No. 9.—Is used for removing the striker case or cap and small screws.

Wrench Aiming Rifle, No. 10.—Is used for adjusting frames and all nuts.

Rifles, aiming, 1-inch—

Brush, cleaning	}	Is used for cleaning the
Rod, cleaning		

When the aiming rifle is used in guns mounted on carriages which are fitted with automatic sights, and to give increased practice in laying with these sights, the ordinary cam of the automatic sights will be substituted by a cam cut to the range limit of the aiming rifle.

CARE AND PRESERVATION.

All actions and parts of the aiming rifle should be kept perfectly clean and oiled, so as to keep them in good working order and prevent rust. No cutting material such as emery cloth is to be used for cleaning.

GUNS, SUB-CALIBRE, Q.F. 3-PR. MARKS I, I* AND III, AND II, II* AND IV.

(Plate V.)

Where specially authorised Q.F. 3-pr. sub-calibre guns are supplied for use with 6-inch B.L. Marks VII and VII^v guns for giving instruction in laying.

Q.F. 3-pr. Hotchkiss and Nordenfelt guns are converted for this purpose and are designated "Guns, sub-calibre, Q.F. 3-pr." Mark I, or Mark II, respectively. The conversion consists in the removal of the trunnions and the substitution of a screwed steel ring by means of which the sub-calibre gun is retained in position in the bore of the B.L. gun.

The principal parts of the sub-calibre guns and separate stores are as follows :—

Guns, sub-calibre, Q.F. 3-pr. B.L. 6-inch, Marks VII, VII ^v , XI and XI ^o guns Mark I ...	converted Hotchkiss; steel with component breech fittings and block catch retaining with bolt, handle and keep pin.
or	
B.L. 6-inch, Marks VII and VII ^v guns, Mark II... ..	converted Nordenfelt; steel with component breech fittings and block catch retaining with bolt, handle and keep pin.

Guns, sub-calibre, Q.F., 3-pr. :—

Mark I:—

Counterweight, B.L. 6-inch, Marks VII and VII ^v guns	steel with securing bolt.
Frame, adjusting, front, B.L. 6-inch, Marks VII and VII ^v guns 	bronze, lightened with set screw.
Ring, preserving, obturator seat, B.L. 6-inch, Marks VII, VII ^v , XI and XI ^o guns	steel.

Mark II :—

Counterweight, B.L. 6-inch, Marks VII and VII ^v guns	steel with securing bolt.
Frame, adjusting, front, B.L. 6-inch, Marks VII and VII ^v guns 	bronze, lightened with set screw.
Ring, preserving, obturator seat, B.L. 6-inch, Marks VII and VII ^v guns ...	steel.
Block, centring, B.L. 6-inch, Marks VII, VII ^v , XI and XI ^o guns 	bronze.
Tool inserting and removing preserving ring, No. 1 ...	steel (bronze for future manu- facture); guns sub-calibre, Q.F. 3-pr.

The "front, adjusting frame" is secured round the muzzle of the sub-calibre gun and serves to prevent injury to the bore of the B.L. gun during insertion or removal.

The "ring, preserving, obturator seat" is placed in the interior of the B.L. gun to prevent injury to the obturator seating of the latter. A tool is provided for inserting and removing the preserving ring.

The "centring block" is placed in the lower plain section of the breech opening of the B.L. gun so as to support the sub-calibre gun in a central position when assembling.

The sub-calibre gun is secured in position in the B.L. gun by the "block retaining catch," which is placed in the upper plain section of the breech opening.

The steel counterweight is secured round the chase of the B.L. gun, when the sub-calibre gun is used, to balance breech preponderance.

The ordinary breech mechanism of the Hotchkiss or Nordenfelt Q.F. 3-pr. gun respectively, is used (for which *see* handbook of gun concerned).

In future conversions to sub-calibre guns, Q.F. 3-pr. Hotchkiss and Nordenfelt guns will be designated Mark III or Mark IV respectively, and will differ from Marks I and II respectively, in being furnished at the rear end of the shrunk collar with a clamping nut and stop screw. The clamping nut will be so arranged that, when screwed home into the breech opening of the B.L. gun, the sub-calibre gun will be secured in a central position in the bore by tightening the clamping nut against the breech face of the B.L. gun.

Existing Q.F. 3-pr. sub-calibre guns, when modified by the addition of the clamping nut, will have a star added to the original Mark of the gun.

Cast iron augmenting strips are attached to the counterweight by fixing screws in the case of Mark I* guns. Special counterweights are required for use with Marks III and IV sub-calibre guns respectively.

INSTRUCTIONS FOR ASSEMBLING AND REMOVING SUB-CALIBRE GUNS.

Before inserting the sub-calibre gun lay the B.L. gun horizontal and remove the breech mechanism.

Insert the "ring, preserving, obturator seat" into the breech opening of the B.L. gun and turn the ring until the flanged portion engages with the recesses in front of the screw threads of smallest diameter and remove the tool.

Insert the centring block into the lower recess in the breech opening with the threaded portion uppermost and to the rear.

Remove the breech mechanism from the sub-calibre gun and insert the gun as follows:—

- (1) Lift the gun by means of two handspikes, one placed under the chase in front of the screwed collar, and manned by two numbers (one on either side), and one placed in the breech end of the bore and manned by two numbers.
- (2) Insert the gun into the breech opening of the B.L. gun until the screwed collar engages with the threads.
- (3) Screw the gun into position by means of a handspike inserted through the mortice for breech block or wedge, until the rear face of the screwed collar is flush with the breech face of the B.L. gun in the case of Marks I and II sub-calibre guns, or until the clamping nut will engage the breech face of the B.L. 6-inch gun when tightened up in the case of Marks I*, II*, III, and IV sub-calibre guns, and the mortice for breech block or wedge is in the vertical position.
- (4) Place the block retaining catch in the upper recess of the breech opening of the B.L. gun and turn down the handle in the case of Marks I and II guns. In the case of Marks I*, II*, III, and IV sub-calibre guns, place the securing block in position through the hole in the clamping nut and tighten the latter against the breech face by means of the "wrench clamping nut."

Replace the breech mechanism of the sub-calibre gun.

The order of removal of sub-calibre guns will be the reverse of the foregoing.

Care must be taken before inserting the "ring, preserving obturator seat" to see that the ring and the seating in the B.L. gun are free from dust or grit.

CARRIAGE, GARRISON, B.L. 6-INCH, C.P., MARK II.

(*Plates VI and VII.*)

The carriage is constructed to allow of 16° elevation, and 10° depression with the shield and 20° without, and to revolve about a central pivot on a series of anti-friction balls. The pivot is contained in the pedestal, which is secured to the emplacement by the holdfast. The gun recoils in a cradle, which is fitted with a hydraulic buffer to limit the recoil to about 18 inches, and with springs to return the gun to the firing position.

The carriage consists of the following principal parts:—Cradle, with hydraulic buffer and running out springs, undercarriage, pivot, sighting platform, traversing, elevating, and elevation indicator gears.

The cradle body is a U shaped steel casting formed to fit the jacket of the gun, and having trunnions to pivot it to the under carriage. Three cylindrical chambers are formed on the underside, a central one for the hydraulic buffer cylinder, and one on each side for the running out springs.

A semi-circular steel band is provided to retain the gun in the cradle body; it is formed with lugs which fit in grooves in the cradle immediately above the trunnions, and is secured by screws; a screwed hole, with a gun metal plug, is formed in the top for the insertion of a No. 2 lifting eye, and two lubricating cups are provided. A metal lined groove is formed in the cradle body and in the band for the guides on the gun jacket. Both the cradle body and jacket are fitted with brass liners to take the bearing of the gun.

A plane for the clinometer is cut on the left hand side, and a sheet steel cover is provided to protect the outer surface of the gun. A vertical projection on each side, just above the trunnion, is specially prepared for the attachment of the sight brackets.

HYDRAULIC BUFFER.

(*Plate VIII.*)

The hydraulic buffer consists principally of a cylinder with stuffing box and gland, a combined piston and rod, valve key and controlling plunger.

CARRIAGE, GARRISON, B.L. 6 INCH, C.P. MARK II.

SCALE = 1/12.

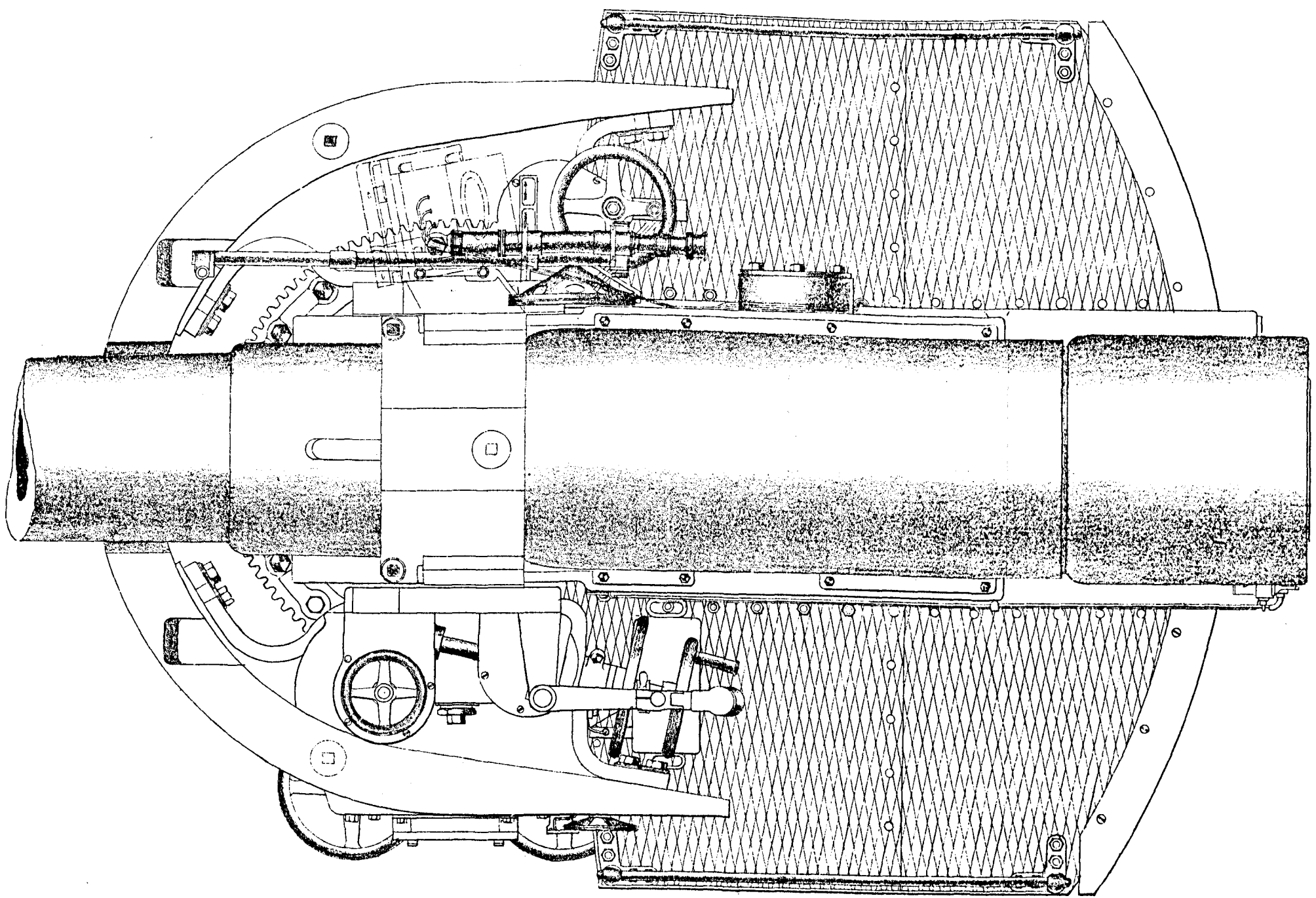

PLAN.

GENERAL ARRANGEMENT OF BUFFER WITH MARK II. PISTON AND PLUNGER.

SCALE = 1/4.

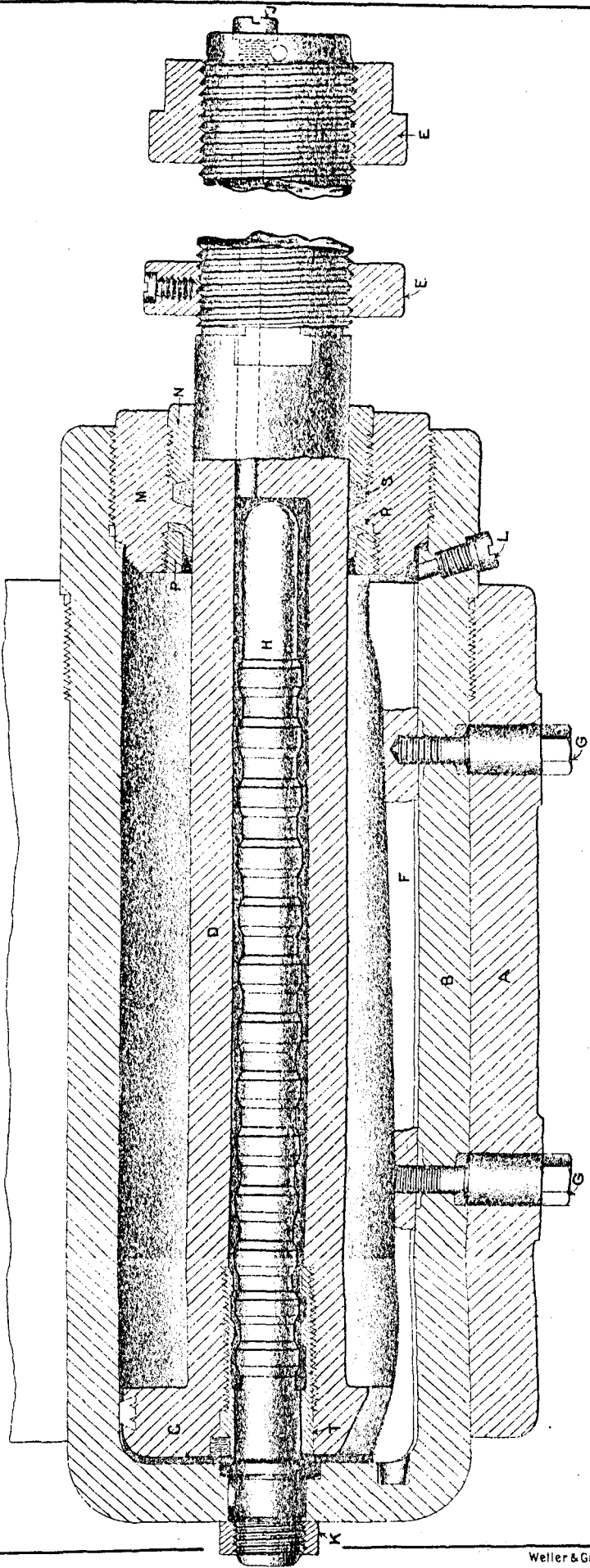

A. CRADLE.
 B. CYLINDER.
 C. PISTON.
 D. " ROD

E. NUTS SECURING PISTON.
 F. VALVE KEY.
 G. SECURING SCREWS.
 H. CONTROLLING PLUNGER.

J. PLUG.
 K. SECURING NUT.
 L. EMPTYING PLUG.
 M. STUFFING BOX.

N. GLAND.
 P. RING SECURING L. LEATHER.
 R. L. LEATHER.
 S. PACKING.
 T. BUSH.

The cylinder is closed at the rear end by a stuffing box and gland, the former having an L leather packing ring secured by a gun metal ring, and an annular space for the greased packing which is compressed by the gland.

The Mark II piston head and rod are in one forging of nickel steel, the head is fitted with a bronze bearing ring and formed with a port to suit the valve key; a cylindrical chamber is formed in the centre of the rod for the controlling plunger, the rear end of the chamber is fitted with a bronze bush which accurately fits the plunger when the gun is in the firing position; 3 radial holes are drilled in the rod adjacent to the head to convey the liquid to and from the plunger chamber; the removal of a screwed plug at the rear end of the rod allows of the expulsion of air from the plunger chamber. Two nuts secure the rod to the lug on the breech of the gun, the larger one at the rear is secured by a keep pin and the other by a set screw.

The Mark I piston is made of inferior steel to that of the Mark II, has a different pattern bush in the plunger chamber, and has no air hole or plug, and no radial hole through the rod into the plunger chamber.

The pistons and control plungers of existing carriages will, when the pistons are found to have expanded to 4.01 inches (and above), be replaced locally by the Mark II patterns, but the old spare pistons must be used up. Mark I controlling plungers must always be used with Mark I pistons.

The valve key is of bronze and is secured by screws to the lower surface of the cylinder, it is formed to fit the sides of the piston port, but varies in thickness and thus regulates the flow of the liquid from one side of the piston to the other during recoil and running up.

The Mark II controlling plunger is of steel, and is secured centrally to the front end of the cylinder by a nut so as to enter the chamber in the piston rod. It is formed with a number of annular grooves, and with a small flat surface lengthways, gradually diminishing towards the front end, which reduces the space for the escape of the liquid from the plunger chamber as the gun runs up. *The Mark I plunger* is shorter than the Mark II, and is tapered at the rear end. A small hole is drilled centrally throughout its length, and another meeting it radially. A plug is screwed into the rear end of the central hole, having a tapered flat cut on its front end and which controls the escape, from the plunger chamber, of the liquid as it passes through the radial and central holes of the plunger.

A tank is formed on the right hand side of the cradle above the hydraulic buffer. It contains a reserve of liquid to replace leakage, and is connected to the buffer cylinder by a suitable passage. The cylinder and tank are filled through a small opening in the top of the tank. The tank is closed by a circular cover which bears the instructions for filling. In certain carriages the hole connecting the tank with the cylinder enters the tank above its lower surface, this defect has been remedied by the addition of a packing plate secured to the bottom of the tank by a screw.

A passage is provided for the exit of air from the cylinder when filling. Also a drain hole for emptying the cylinder, each being closed by a screwed plug.

Running out springs (Plate IX).—These consist of two sets, each set being self-contained. A set comprises 4 springs separated by dividing bushes, and mounted on a compressor rod and nut. The rod is screwed for a considerable portion of its length, and engages with the nut, which is a flanged tubular casting of gun-metal. The springs are compressed between the flange of the nut and an end plate which bears against a screwed ring in the spring chamber. The end of each rod is secured to a cross bar which is fixed to a projection on the rear end of the gun by screws.

ACTION OF BUFFER AND SPRINGS.

When the gun recoils on firing, it draws the piston and spring rods with it to the rear; the liquid in the cylinder, in passing from the rear of the piston to its opposite side, is forced through the space between the port in the piston and the valve key, which, owing to its shape, gradually closes the opening, and brings the gun to rest. Meanwhile, the plunger chamber in the piston has become filled with liquid, and the running out springs have been further compressed, their subsequent expansion causes the gun to return to the firing position, and in doing so, the plunger displaces the liquid in the piston, the space for its escape is gradually reduced by the tapering of the flat on the plunger, which results in the gun being gently brought to rest in the firing position. With the Mark I plunger, the liquid escapes through its centre and connecting radial holes to the cylinder; the size of the small flat on the plug determines the cushioning effect.

UNDER CARRIAGE.

The under carriage consists of a circular cast steel socket, to which is secured two upright side plates. The socket is formed to fit over the upper end of the pivot, and is provided with gun metal bushes. The weight of the carriage and gun are supported on a series of anti-friction balls contained in a circular groove formed in the top of the pivot, and a bearing plate fixed to the top of the socket. The balls are arranged to roll between two hardened steel rings, one in the socket and one in the pivot, the rings were originally fixed in position by a small portion of the pivot and bearing plate being spun over the outside edge of the rings, but in future, and when existing rings require replacement, they will be fitted into the recesses without being secured, and holes (with preserving screws) will be drilled in the bearing plate, and plain holes in the pivot, to facilitate the removal of the rings. A small cover plate is secured by screws to the top of the bearing plate to protect the lifting hole in the upper end of the pivot. The upper end of each side plate is formed with a bearing for the trunnions of the cradle, and fitted with gunmetal capsquares.

On the left hand side plate, gun metal brackets are bolted, for carrying the elevating and traversing gears; the upper brackets are formed as boxes with covers for enclosing the gears, and

GENERAL ARRANGEMENT OF RUNNING OUT SPRINGS.

SCALE = 1/8.

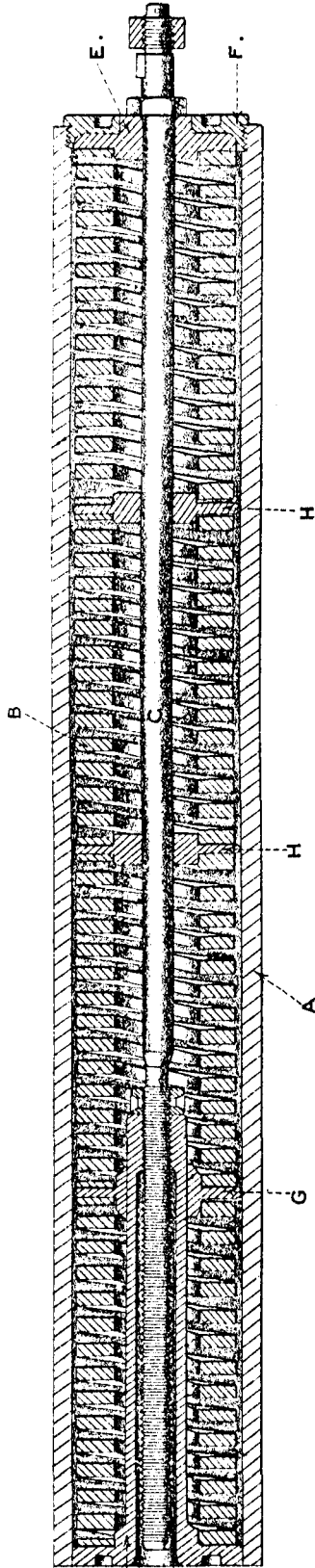

- A. CRADLE.
- B. SPRINGS.
- C. RUNNING OUT ROD.
- D. COMPRESSOR NUT.
- E. END PLATE.
- F. COVER.
- G. DIVIDING BUSH, FRONT.
- H. " " REAR.

releasing a clamping arrangement contained in the hollow of a worm-wheel; this arrangement consists of a series of steel and metal discs, which are placed together or released by turning a small hand-wheel, which is at the front of the carriage on the left hand side. Carriages, which are served by a P.F., are fitted with pointers having deflection scales to indicate the angle of traverse. The pointer is constructed to indicate a deflection of 3 degrees right or left independently of the angle of traverse ordered. Each pointer consists principally of a bracket which carries a screw with a nut, and a scale plate; the nut is formed with two projections, one of which indicates the amount of deflection on the scale plate, and the other the angle of traverse ordered on the traversing arc.

ELEVATION INDICATOR GEAR.

The elevation indicator gear is used to indicate the angle of elevation in yards when not using the sights for giving elevation. It is intended to be used when operating the elevating gear from the emplacement. It is actuated by the oscillating movement of the cradle in the trunnion bearings as the gun is elevated or depressed. It consists principally of a bronze toothed arc fixed to the underside of the cradle and gearing with a pinion on a cross shaft. To the left hand end of the shaft is fixed a disc with a detachable yard scale plate. The face of the plate is formed with a spiral groove. A slide for carrying a reader is fixed to the left hand shaft bracket. The slide extends across the face of the scale plate, and is formed with a groove, radial to the scale plate, to hold a reader having an indicating arrow. The reader has a projection which fits into the spiral groove in the scale plate, and moves backwards and forwards in the slide as the plate is turned. A spiral spring to obviate errors due to backlash is provided, having one end of it attached to the shaft, and the other end to a gunmetal case at the right hand end of the shaft.

Yard scale plates are provided for use with the indicator as follows:—

	M.V. in F.S.	Range.	No.	Remarks.
Full charge	2,493	12,000 yds.	1	} according to weight of charge used.
Half-charge, 10lb. ...	1,625	7,500 yds.	1	
Half-charge, 11½lb. ...	1,570	8,000 yds.		
Sub-calibre, gun, Marks I, I* and III. ...	1,875	5,500 yds.	1	} according to Mark of gun used.
Sub-calibre, gun, Marks II, II* and IV ...	1,946	4,000 yds.		

When securing a yard scale plate to the disc, the arrow of the reader must point to a red zero line on the plate when the gun is horizontal.

CARRIAGE, GARRISON, B. L. 6 INCH, C. P. MARK II.
GENERAL ARRANGEMENT OF ROCKING BAR SIGHT.

SCALE - $\frac{3}{16}$.

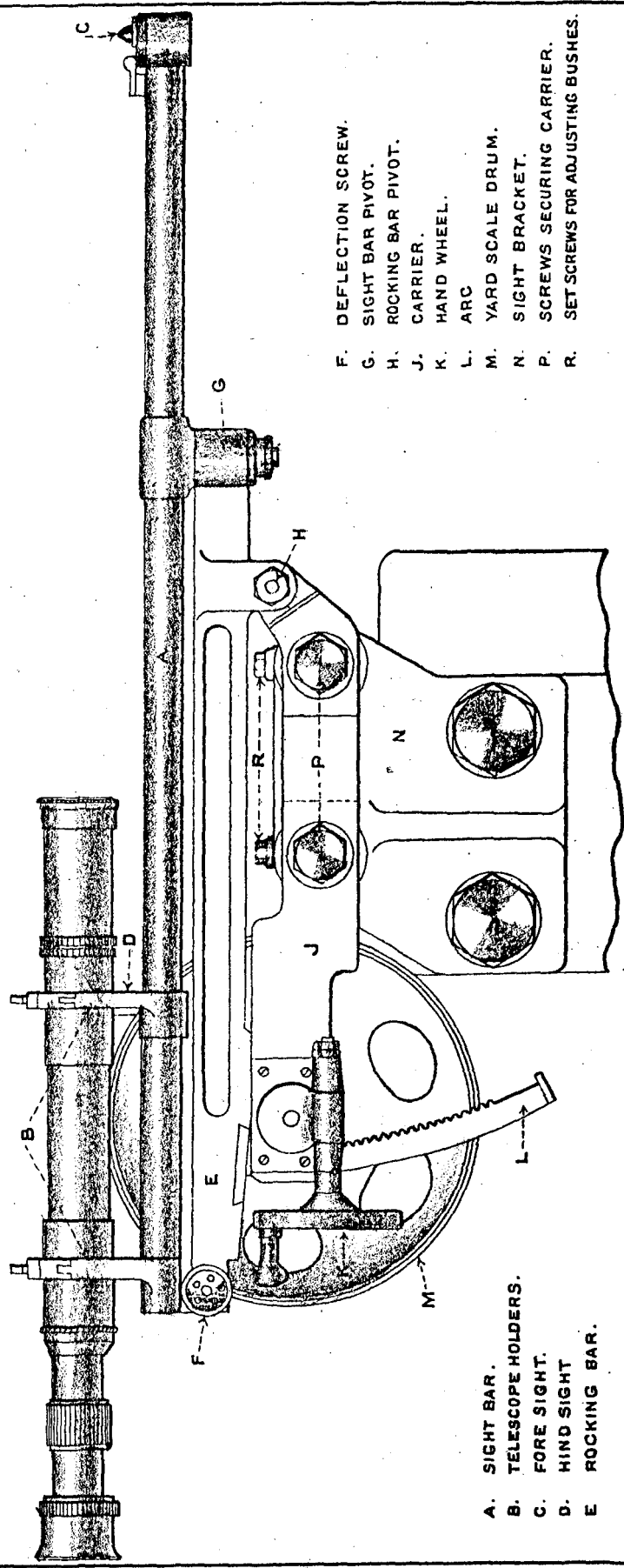

- F. DEFLECTION SCREW.
- G. SIGHT BAR PIVOT.
- H. ROCKING BAR PIVOT.
- J. CARRIER.
- K. HAND WHEEL.
- L. ARC
- M. YARD SCALE DRUM.
- N. SIGHT BRACKET.
- P. SCREWS SECURING CARRIER.
- R. SET SCREWS FOR ADJUSTING BUSHES.

- A. SIGHT BAR.
- B. TELESCOPE HOLDERS.
- C. FORE SIGHT.
- D. HIND SIGHT
- E. ROCKING BAR.

CELLULOID SCALES FOR YARD SCALE PLATES.

Celluloid scales will be provided for full and reduced charges, and sub-calibre guns, when regraduation is necessary, and for 1-inch aiming rifle practice.

The scales will be made, and the celluloid obtained, locally.

Instructions for Fitting.

To cut the spiral groove in the celluloid disc:—After having first obtained an impression of the existing groove in the plate, yard-scale, by means of paint or other suitable marking material available, drill a number of small holes where the groove is to be cut, then blend the holes together with a small round file, care being taken to leave the groove a little narrow to required finished size.

To secure the celluloid disc to existing plate, yard-scale:—Thoroughly clean the face of both the plate and celluloid disc with emery cloth (care being taken that they are free from grease), then warm the plate sufficiently to thoroughly melt ordinary shellac, giving the surface a very thin coating. When cold, give the surfaces to be stuck together a coat of liquid shellac (*i.e.* shellac dissolved in spirit of wine). When tacky, placed the celluloid disc in correct position to suit groove, then carefully weight with something having a flat surface. The disc should be further secured by small countersunk head screws on each spiral of the plate.

To complete:—Cut the groove in disc to full width of existing groove in plate. Pack up the arm carrying the reader with the equivalent thickness of celluloid disc.

SIGHTS AND SIGHTING GEAR.

(Plate X.)

The carriage is provided with a rocking bar sight on the right hand side, and an automatic sight and gear on the left hand side.

The *rocking bar sight* consists principally of a sight bar, rocking bar, and carrier, the whole being secured to a bracket which is fixed to the top of the cradle.

The sight bar is of steel tubing pivoted vertically to the rocking bar so as to admit of horizontal movement for deflection; the front end is fitted with an acorn-pointed foresight having a protecting cap, and the rear end with two holders and hinged caps for securing a telescope; the front holder is fitted with a V-notched leaf for use as a hind sight.

The rocking bar is pivoted horizontally to the carrier so that the rear end may be raised or lowered according to the range; the pivot for the sight bar is formed at the front end; to the underside of the rear end is attached a toothed arc, having for its centre the pivot of the rocking bar and carrier; the rear end is formed with a crosshead having a deflection screw with milled heads, the screw works in a nut which moves the sight bar to the right or to the left. The amount of deflection is indicated by a scale plate on the rocking bar and an arrow head. The space between each of the markings is equal to 10' deflection. The total deflection is 2° right and left.

The carrier is of steel plate and secured by eccentric bushes and nuts to the carrier bracket on the cradle; the rocking bar is pivoted to the front end, and to the rear end is secured a metal bracket containing a worm and worm-wheel gearing in each other; the worm is mounted on a spindle having an actuating hand-wheel at its rear end; to the spindle of the worm-wheel is fixed a pinion which gears into the teeth of the arc on the rocking bar, also a drum on which is mounted a detachable yard scale ring; the ring is secured to the drum by screws with nuts, the latter fit in a dove-tailed groove formed round the drum.

Four yard scale rings are provided as follows:—

Nature.	M.V. in F.S.	Range.	No.	Remarks.
Full charge	2493	12,000 yds.	1	According to weight of charge used.
Half-charge, 10lbs.	1625	7,500 "	1	
Half-charge, 11½lbs.	1570	8,000 "		
3-pr. sub-calibre gun, Marks I, I* and III	1875	5,500 "	1	According to Mark of gun used.
3-pr. sub-calibre gun, Marks II, II* and IV	1946	4,000 "		
1-inch aiming rifle	1100	2,500 "		

The sight bar moves in a plane inclined $1^{\circ} 30'$ to the vertical plane to compensate for drift due to rifling.

Automatic Sight and Gear.—Full description is given in the Handbook of the Automatic Sight.

INSTRUCTIONS FOR CHANGING CAMS.

For Carriages fitted with Correcting Gear:—

- (1) To remove the spring case:—Remove the keep pin and collar from the axis stud on the sight bracket. Elevate the gun to compress the spring in its case, and pass a wire nail (or a piece of wire of suitable dimensions) through the hole in the outer case to retain the inner case. Depress the gun until the front end of the spring case falls clear of the stud on the cam roller lever, and remove the case from its axis stud.
- (2) To remove the cam adjusting lever:—Unclamp the "stud, cam, adjusting lever" by the handle, and unscrew the two nuts on the end of the stud. Force the stud through the bracket towards the left, and remove the two nuts. Remove the cam adjusting lever.
- (3) Elevate the gun to about 15° . Remove the cam hinge stud. Raise the cam and remove it outwards.
- (4) To mount the required cam with its adjusting lever, the order of the instructions detailed above is reversed. Care must be taken that the cam roller and the driving edge of the cam are quite clean.
- (5) *NOTE.*—The same cam adjusting lever is used for both full and half charges, but special adjusting levers are provided for the aiming rifle and sub-calibre gun.

- (6) After changing a cam, adjust the sight as described in "Regulations for Magazines and Care of War Matériel."

For Carriages not fitted with Correcting Gear, proceed as follows:—

- (1) As in "(1)" above.
- (2) Remove nut and clip from adjusting lever.
- (3) Remove the nut and collar from the adjusting lever stud, and remove the adjusting lever. Remove the cam hinge screw together with the cam.
- (4), (5) and (6). As above.

A *hinged step* is provided locally to facilitate the inspection and adjustment of the sights.

ELECTRIC FIRING GEAR.

(See also "*Regulations for Magazines and Care of War Matériel.*")

The gear is arranged on the carriage so that the gun can be fired from either side of, or below, the platform. But, if not connected with a P.F. station, provision is not made to fire from below the platform.

The gear consists generally of a 4-cell electric battery, a battery box with connections, 3 pistol grip connectors, a pistol grip, safety plug box, sliding contact, and a series of cables.

The *battery* consists of 4 Leclanché cells of the agglomerate pattern (Leclanché, A, Mark III) contained within the battery box; the cells stand on strips of rubber, and are separated from each other by a strip of felt; they are connected up in "series," being earthed by a copper strip at one end of the box. The box is made of galvanised steel plate, and is supported on the sighting platform.

Secured to the box is a "connection, cable to battery box," from which the current is distributed by cables to the several pistol grip connectors.

The *pistol grip connectors* are each similar in pattern; one is secured to the bracket carrying shoulder-piece on the left hand side, another to the upper traversing gear bracket on the right hand side, and a third to a holder on the traversing gear bracket below the platform. Each connector is formed for the contacts on the pistol grip. Each contact is insulated and prepared for the reception of a cable, one from the battery box, and one to the safety plug box. The pistol grip is secured in position by a set screw and jamming block, and a cover is provided to prevent the ingress of dirt, etc., into the recess for the pistol grip.

The *pistol grip* is used to test the tube and circuit immediately before firing, and for firing the tube. It consists principally of a casing of an alloy of aluminium with two contacts, indicator, contact lever, trigger, and a series of contacts and springs within the casing. The two contacts are formed to fit the contacts of the pistol grip connector. The indicator is contained within a separate detachable case, and is so constructed as to show alternately black and white sectors, a cover plate is provided which can be used to reflect the sectors in a convenient direction. The contact lever, when depressed, completes the circuit through the indicator, the trigger being used for firing the tube.

Action.—(When a tube is in the gun, or the needle of the striker earthed) by gripping the handle the contact lever is depressed, the circuit through the indicator is completed and the white sectors should be showing; by pulling the trigger, the indicator is cut out of the circuit and the tube fired.

The *safety plug box* is used as a junction box for the cables from the pistol grip connectors and sliding contact.

The *sliding contact boxes*, plate and plug, are attached in brackets, the former to the left hand rear end of the cradle, and the latter to the crossbar of the carriage; the plate box contains a rubbing plate, insulated and prepared for the attachment of a cable; the plug box contains an insulated spring plug having a suitable connection for the A cable. The contacts are so arranged that when the gun is in the firing position, contact is made, but immediately the gun leaves that position, contact is broken.

The components of the gear described above are connected up by a series of cables as described hereafter. Each cable, except A, is provided with pin contact terminals, and gunmetal connecting screws to secure the cable in position; each connecting screw is stamped with a letter corresponding with a similar letter on the component to which it is attached. The cables, excepting A, are protected by wire braid covering. The A cable is expendable, its terminals are of stamped sheet brass shaped to suit the contacts on the gun and sliding contact.

List of Cables.

Letter.	No.	Length.		Colour.	Distribution.	
		ft.	in.		From.	To.
A	—	4	10½	Uncoloured	Gun	Sliding contact plug.
B	3	5	8	Purple	Sliding contact plate	Safety plug box.
C	3	7	10	Red	Right hand pistol grip connector	Safety plug box.
D	3	7	1	Yellow	Right hand pistol grip connector	Battery.
E	3	—	11	Black	Left hand pistol grip connector	Safety plug box.
H	3	3	3	Uncoloured	Left hand pistol grip connector	Battery.
J	5	5	8	Blue	Lower pistol grip connector	Safety plug box.
K	5	3	10	Green	Lower pistol grip connector	Battery.

RANGE DIALS (D.R.F).

Fittings are attached to the carriage for carrying a dial box "C" in either of the following positions :—

- (1) On the right hand side of the shield, for use in conjunction with the rocking bar sight.
- (2) On the left hand side below the platform, for use in conjunction with the elevation indicator gear.

A terminal board is fixed to the platform, to the rear of the gun, so that the cables can be connected to it from the dial box in either position, and with the mechanical dial in the emplacement.

RANGE DIALS (P.F.).

When served by a P.F., the dial boxes are attached to the carriage so that they can be conveniently read at any position in the arc of traverse, by the men serving the gun. Carriers are fitted, two to the carriage below the platform adjacent to the elevating and traversing hand-wheels, and one to the shield on the right hand side ; the carriers can be used as required.

SHIELD.

The shield consists of a U-shaped steel plate tapered at each end ; the front is cut away for the chase of the gun to admit of 10 degrees depression, but may, when necessary, be cut away to allow of 20 degrees ; the inside is also cut away to clear the sighting and elevating gears ; it, however, will not be cut (to clear the sight bar) to give a greater angle of depression to the gun than the slope of the parapet will admit ; to limit the depression when the gun is out of action, and prevent damage to the sight, a stop will be placed in the opening in the shield for the gun to bear against ; this stop will be made and fitted locally as required. The shield is supported by curved stays bolted to the under carriage. There is a hole in the top edge, each side, for lifting eyes.

Bridge protecting sights.—The shield is provided with a bridge of T-steel to protect the sights when putting on or taking off the carriage cover.

The following are provided :—Pedestal, levelling ring, holdfast, traversing arc, cover, and special implements.

PEDESTAL, CARRIAGE, No. 2.

Mark II pedestal is of cast iron, having in the direction of its length strengthening webs ; one of the webs is provided with a hole for lifting purposes. In later manufacture, it will be fitted with screwed holes in the upper flange so that No. 2 lifting eye can be used when slinging the pedestal. It is formed at the lower end with a flange which is prepared for the holding down bolts of the levelling ring and holdfast and at its centre for the pivot ; the traversing rack is bolted down on the top edge ; drain holes are provided ; there are also three holes tapped for the levelling screws, which are of steel, with hardened steel points, and are intended to allow of the pedestal being raised for the insertion of packing as required, when necessary to level the carriage for automatic sights.

Mark I is not so strong as Mark II ; it is formed at the upper end to receive a supporting plate for traversing rack.

RING, LEVELLING, No. 2 CARRIAGE PEDESTAL.

The levelling ring is of cast iron, 4 inches thick, and is secured immediately under the pedestal.

Levelling the Pedestal.—See “Regulations for Magazines and Care of War Matériel.”

HOLDFAST, CARRIAGE PEDESTAL, No. 2.

The holdfast consists of seven anchoring plates and 28 holding-down bolts; the bolts are bulb-headed with key for recess and keyway in the anchoring plates, and in the latest manufacture a cotter is provided which passes through each bolt above the anchoring plate; six of the bolts have two nuts each, the others one, the six extra nuts being screwed down below the levelling ring so as to steady the holdfast while being embedded in the concrete to the level of the ring. The upper ends of the bolts pass through the levelling ring and the pedestal, the whole system being secured by nuts which are screwed on the bolts above the flange of the pedestal.

Weight of { Bolts, holding-down, 15-cwt. 2-qr. 20-lb.
 { Plates anchoring, 10-cwt. 3-qr. 4-lb.

ARC, TRAVERSING, No. 37.

The arc is made of gunmetal, and is graduated in degrees which are sub-divided into $\frac{1}{4}$ -degrees. It is secured to the top of the pedestal. The angle of traverse is indicated by a pointer (*see* page 24).

COVER, CARRIAGE.

The cover is of waterproof canvas, and is for protecting the carriage. The Mark II differs from the Mark I in being made of three pieces so as to facilitate removing and replacing. It is secured in position by two 2-ft. lengths of 1-inch tarred lashing.

SPANNERS AND SPECIAL IMPLEMENTS, &c.

Spanners—

- No. 48 ... for holding-down bolts of carriage pedestal.
- No. 175 ... for adjusting automatic sight gear.
- No. 186 ... for spring compressor and cover for springs.
- No. 187 ... for elevating pinion.
- No. 188 ... for nut plunger controlling running out.
- No. 190 ... for sighting gear.

Spanners, hydraulic buffer—

- No. 44 ... for piston rod nut.
- No. 97 ... for stuffing box, piston rod, gland and ring securing leather packing.

Screwdriver—

- No. 10 ... for small screws of automatic sight gear.
- No. 13 ... for air, filling, and drain plugs, and screws of contact boxes.

Eye, lifting—

- No. 1 ... for pivot.
- No. 2 ... for cradle, shield, and pedestal.

Wrench—

- No. 6 ... for screws, band retaining gun in cradle, and preserving holes for lifting eye.

PARTICULARS OF B.L. 6-INCH C.P. MARKS I AND II MOUNTINGS FOR LIFTING PURPOSES.

Weight and Centre of Gravity of Main Portions.

Names of main portions.	Mark I.	Mark II.	Vocab. No. of lifting eyes where provided for.	No. of lifting eyes used.	Centre of Gravity.	Remarks.
	Average weight.	Average weight.				
Cradle with 2 presses running out and hydraulic buffer	cwts. qrs. 36 3	cwts. qrs.	16 inches in rear of centre line of trunnions.	
Pivot	15 3	45 3	2	1	...	
Shields without stays	41 2½	15 3	1	1	...	
Under carriage with fittings	42 3	84 0	2	2	32 inches from lower edge of shield.	Centre of gravity is given for the under carriage stripped of all its gears and sighting platforms.
Holdfast, carriage pedestal, No. 2	26 2	38 1	1½ inches in front of centre line of trunnion.	
Pedestal, carriage, No. 2 (a) (b)	129 0	26 2	2	2	0.65 inch in front of centre line of trunnion.	
Ring, levelling, No. 2 carriage pedestal	25 0	129 0	
		25 0	

(a) Where the pedestal is not prepared for lifting eyes in accordance with para. I. of C. 11565, the holes in webs should be used for the purpose.

b) For weight of pedestal with lightening holes in webs deduct 4½ cwts.

APPARATUS TESTING GUN LAYER.

The apparatus is used to facilitate the testing and instruction of gun layers with the automatic sight as laid down in G.A.T., Volume I.

The apparatus consists of a pointer and a graduated scale plate. The pointer is pivoted to the centre of the elevation indicator gear shaft, and is clamped to the yard scale plate and disc by a spring and bolt attached to a clamping block. The scale plate is fixed to the shield, and is formed with a stop at each end for the pointer; it is graduated in minutes and half-minutes and reads up to 20 minutes on one side of zero and 15 minutes on the other.

APPARATUS WITHDRAWING GUN FROM CRADLE.

The apparatus is for drawing the gun a certain distance to the rear in its cradle (without the aid of a working party), so as to facilitate the examination, or repacking of the glands and stuffing box of the hydraulic buffer cylinder. If the stuffing box is to be removed, the gun must, during the operation, be slightly depressed and blocked up, so as to prevent all possibility of its being elevated above the horizontal.

It consists of a clip, bracket and screw. The clip is placed over the lug on the rear end of the left spring case; the bracket is secured to the crossbar connecting springs, and the screw connects the bracket and the clip. On turning the screw (the nuts on the rods running out springs first being removed), the gun, with piston rod and crossbar, is drawn towards the rear.

The gun may be withdrawn to a distance of about 18 inches if necessary.

The sliding contact fittings on the spring case and crossbar must be temporarily removed when using the apparatus, one of the screws of the contact fittings being used to secure the bracket of the apparatus in position.

BAR TESTING SIGHTING GEAR, AUTOMATIC AND ROCKING BAR.

The bar is for use in testing, by means of the service clinometer, the accuracy of the telescope holders on the automatic and rocking bar sights, it is formed to fit the telescope holders, and with a plane for the clinometer. An arrow head is engraved on the rear end, which will be set to correspond with a similar arrow head on the rear telescope holder.

When testing the angle between the gun and the sight the clinometer readings will be taken from the bar fixed to the holders.

HOLDERS.—SIGHT CAM, SIGHT BAR, AND BAR TESTING SIGHT.

The holders are of wood, and are formed to protect the cams, sight bars and bar testing sight when they are not in use on the carriage.

BOX SPARE PARTS.

The box is in the form of a tray, divided into compartments, for the reception of spare springs and other small spare parts belonging to the gun.

TRAY SPARE PARTS.

The tray is similar to the above-mentioned box and is intended to hold the spare parts of the carriages in a work.

TRAY STORES.

The trays are for use in holding stores and spare parts for the service of the gun, and will be brought up to the gun when required for use.

CARE AND PRESERVATION OF CARRIAGE, SIGHTS, &c.

(See also "Regulations for Magazines and care of War Matériel.")

The circular grooves, containing the anti-friction balls must be kept filled with mineral jelly to act as a lubricant and to prevent the ingress of water. The grooves and balls must be perfectly clean and dry before inserting the jelly.

Shafts and spindles having nuts secured by taper pins will be marked to correspond with each other to prevent the nuts being placed on the wrong shafts or spindles. When necessary, nuts, shafts, or spindles will be marked locally with a letter or punch mark as most convenient.

Whenever any parts are found broken, defective or deficient, which cannot be renewed by the artificer, fresh parts should be demanded at once. Any damage occurring at drill or practice should be at once reported, with a view to its being made good without delay.

To Replace Packing of Hydraulic Buffer.—To give sufficient space to work at the glands it may be necessary to disconnect the cross-bar from the rods of running out springs and the gun from the hydraulic buffer, by removing the nuts; this will allow the gun to be run back, which should be done with care, with the apparatus described at page 32. Then pull out the piston rod a few inches, unscrew the gland, and remove the old packing. Clean out the stuffing box, slightly coat it and piston rod with mineral jelly. Pack stuffing box with new greased packing, which is $\frac{1}{2}$ -inch square in section; 36 inches will be required, which will be cut into lengths forming two rings, each about equalling the circumference of the piston rod; the cuts will be made diagonally, so as to overlap when the piece is formed into a ring; well tallow each ring, press them successively into the stuffing box with a piece of

wood, taking care that the joint of one ring is well separated from that of the other, so as to break joint; screw home the gland, but not too tightly at first which would prevent free action of piston rod. The bright parts should be coated with mineral jelly, and the gun connected up as previously. Spanners, *see* page 30.

To Replace Leather Washer, or "L" Leather.—The gun must be disconnected and placed in a convenient position as before mentioned. Empty the buffer by removing the plug of emptying hole and give air passage by releasing the filling hole plug on top of tank. Unscrew stuffing box and move it to the rear to allow the leather washer to be taken out from the front, unscrew the metal ring and take out the L leather. The leathers are examined, and, if unserviceable, are removed; coat the new leather with dubbing; place the packing ring in position. Place the securing ring, L leather, and stuffing box on the piston rod; secure the L leather in the stuffing box, by the securing ring; screw up the stuffing box; connect up the gun as before, and fill the buffer as hereafter described.

To Replace Leather Washer of Tank Cover, &c.—Run off about 7 pints of oil as described for emptying the buffer, when the plug can be removed, and the washer replaced; secure the cover and refill buffer.

To replace leather washer on emptying hole plug the buffer will require emptying, but that of the filling hole can be replaced by simply removing the plug.

Controlling plunger.—In cases where it is found that the guns do not run up to the front stops, a flat surface will be filed on the Mark II controlling plunger, or screw plug of Mark I controlling plunger; too much metal must not be removed, or the gun will run up to the stops with violence.

To fill the buffer.—Carriages with Mark I piston and controlling plunger:—

Depress the gun, loosen the air plug and fill through the hole on top of tank at right side of cradle until the oil overflows through the air hole; replace the air plug and fill the tank. Draw off half a pint, and replace filling hole plug in tank.

Carriages with Mark II piston and controlling plunger:—

Depress the gun, loosen the air plugs in cradle and rear end of piston rod. Fill through the hole in the top of tank at right side of cradle until the oil overflows at air hole in piston rod. Replace air plug in piston rod. Proceed with the filling until the oil overflows at air hole in the cradle. Replace air plug in cradle and fill the tank. Draw off half a pint and replace filling hole plug.

The liquid should be strained before entering the buffer.

Contents—about 3 gallons of mineral oil.

The greatest care must be taken of the projections above the trunnions and the sight brackets, as any indentations or disturbance of the surfaces will affect the accuracy of the sights.

Handbook of the 6-inch B.L. Guns, Marks VII & VIIv (Land Service).

1911.—AMENDMENTS.

Page 55, line 18 from bottom—

Delete " a " and *insert* " an electric."

After " percussion firing " *insert* " presses the extractor well home and ".

Page 56, line 2—

After " percussion firing " *insert* " 2 closes the breech until the lock commences to rise, inserts the percussion tube, and finishes closing the breech."

Line 11—

After " tube " *insert* " It is also most essential that the percussion tube shall not be inserted until the breech has been closed and the lock has started to rise, as there is great danger of the tube firing prematurely when the breech is slammed. An unfired percussion tube will always be removed before the breech is opened."

Page 59, line 6, *after* " changed " *insert*—

" An unfired percussion tube will always be removed before the breech is opened."

TELESCOPES, SIGHTING. FOR ROCKING BAR AND AUTOMATIC SIGHTS.

The following telescopes can be used :—

No. 1, Marks I, I*, II and III.

No. 3, Marks I and II.

TELESCOPES, SIGHTING, No. 1.

Particulars.

Magnification	3 diameters.
Field of view	10 degrees.
Length over all... ..	24 inches.
Weight	7 lbs.

Mark I telescope is of the ordinary erecting type, with an object glass and terrestrial eyepiece.

The body is fitted with two long gunmetal collars which accurately fit the bearings on the sight bar, but allow three inches of movement backward or forward to suit the convenience of gun layers.

The eyepiece is fitted with a fixed dermatine eyeguard.

A diaphragm carrying a diamond shaped pointer is fixed between the third and fourth lenses of the eyepiece.

The object glass is fitted in an eccentric cell and ring, and is fixed in the correct position for infinite focus, or, in other words, for all objects over 400 yards distant. It is protected by a ray shade and metal cap.

*Mark I** telescope differs from *Mark I* in having a detachable dermatine eyeguard.

Mark II telescope differs from *Mark I** in having improved focussing arrangements. The turning movement of the eyepiece can be read off on an engraved ring, numbered 0 to 7 in conjunction with an arrow on the body, 4 being the position for normal vision, so that individual layers may set their focus to the figure previously determined.

The pointer is fixed at the focal length of the object glass.

Mark III telescope differs from *Mark II* in the diaphragm, which carries the pointer, being made adjustable so that collimation may be carried out by means of the diaphragms, instead of by rotating the object glass in eccentrics.

TELESCOPES, SIGHTING, No. 3.

Particulars.

Magnification	10 diameters.
Field of view	3½ degrees.
Length over all	24·5 inches.
Weight	7 lbs.

Mark I telescope is generally similar in construction to No. 1, *Mark II*; but differs in having a triangular shaped pointer.

No. 3, *Mark II* telescope differs from *Mark I* in the diaphragm which carries the pointer, being made adjustable by four screws, as in No. 1, *Mark III*.

To focus the telescope.—No. 1, Marks I and I^o. Screw the eyepiece in or out until the pointer is clearly defined.

No. 1, Marks II and III, and No. 3, Marks I and II.—Revolve the eyepiece tube by means of the knurled ring to the graduation required.

CARE OF TELESCOPE.

For care and preservation of telescope, sighting, *see* “Instructions” contained in telescope case; *also* “Regulations for Magazines and Care of War Matériel.”

Test for collimation.—Lay the tip of the pointer on a well defined point some distance away, the further away the better, and turning the telescope completely round in its bearings, the tip of the pointer should remain on the distant object if correct for collimation.

GUN AMMUNITION.

Description.	Projectiles.			Nature of fuze.	Cartridges.			Means of firing.	
	Marks.	Weight filled and fuzed.	Bursting charge.		Nature.	Weight.	Size.		
			Nature.						Weight.
Shell, armour piercing, with cap ...	V	100 0	2 9	blank L.G.	lbs. ozs.				
Shell, armour piercing	II and III	100 0	5 8	(blank L.G. R.L.G., L.G., R.L.G. or R.L.G. ² .)	Base, large, No. 15				
" common lyddite	I and II, III and IV, VI	102 4 101 2 100 0	13 12 10 6 10 7	lyddite	" " 11				
" shrapnel forged steel	IV	100 8	including exploder 0 10½		D.A. impact, No. 15	Cordite or Cordite M.D.	20 0 23 0	20 16	
" cast steel	V-IX	100 8½	0 10½	R.F.G. ²	T and P No. 64			V.S. electric wireless P tube or V.S. percussion tube.	
Shot, practice ...	I	100 0	—	R.F.G. ²	—		44 0	—	
" paper ...	IV	120 0	—	—	—		7 0	—	

Note.—Items printed in italics are obsolescent.

* Issued only when specially ordered.

AMMUNITION FOR RIFLE, AIMING, 1-INCH ELSWICK "B" MARK I.

Description.	Mark of cartridge.	Weight of bullet.	Charge.	Means of firing.
Cartridge—		oz. grs.		
Aiming rifle, 1-inch electric	9 408	400 grains R.F.G. ² powder
" " blank	IV and V I	—	" " " " " " " "	Electric primer. " " " "

CARTRIDGE, B.L. 6 INCH. GUN, 11½ LB. CORDITE, M.D. SIZE 16, MARK I.

SCALE = 1/3.

- GUNPOWDER.
- FELT WADS.
- SILK CLOTH DISC.
- SHALLOON DISCS.
- SILK CLOTH RINGS.

- SILK SEWING
- CORDITE

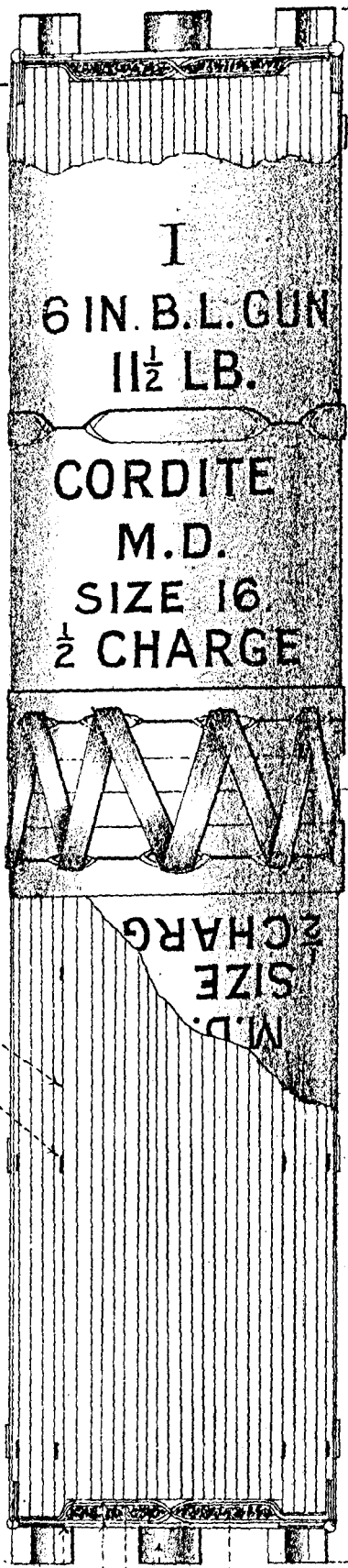

12.7"

12.7"

NOT TO EXCEED 25.5"

CARTRIDGE, B.L. 6-INCH, GUN, 10 LB. CORDITE, SIZE 20 MARK I.

SCALE = 1/3.

- GUNPOWDER.
- FELT WADS.
- SILK CLOTH DISC.
- SHALLOON DISCS.
- SILK CLOTH RINGS.

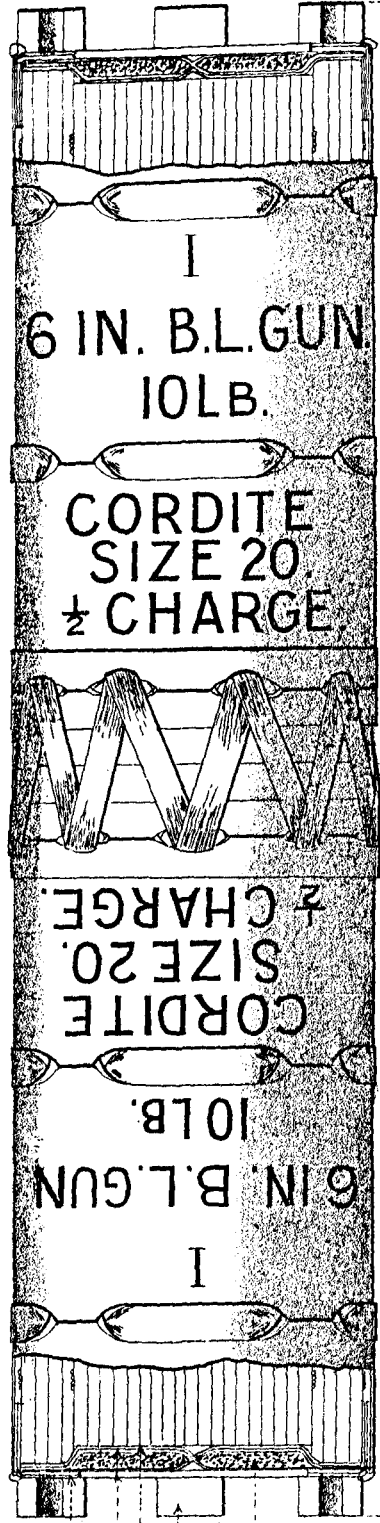

11.75"

11.75"

NOT TO EXCEED 23.6"

CARTRIDGE, B.L., 6-INCH, GUN, 11½ LB. CORDITE, M.D. SIZE 16,
MARK I. (HALF-CHARGE.)

(Plate XI.)

Two half-charges are laced together to form a full charge.

Each half-charge consists of a bundle of cordite sticks tied together with sewing silk. The sticks in the centre of the charge are slightly shorter, thus forming a circular recess at one end for the igniter. The cordite sticks are enclosed in a silk cloth cartridge, hooped with silking or shalloon braid. The igniter (2 oz. of † S.F.G.² powder) is contained in a circular shalloon pocket divided into four compartments by stitching across the centre, and rests in the recess formed at the end of the short length of cordite sticks. A ring of silk cloth having four perforated felt wads sewn to it, is stitched round the igniter end of the cartridge intended to prevent the heated axial vent pressing against the igniter.

This cartridge will be used when existing 10 lb. cordite cartridges are used up.

Packed two half-charges laced together in a No. 34 cartridge cylinder.

CARTRIDGE, B.L., 6-INCH, GUN, 10 LB. CORDITE, SIZE 20,
MARK I. (Half-Charge.)

(Plate XII.)

This cartridge is similar in construction to the "11½ lb. Cordite M.D. size 16 cartridge," described above, differing only in dimensions, and the weight, nature, and size of the cordite.

Packed two half-charges laced together in a No. 34, 38 or 38A cartridge cylinder.

CARTRIDGE, B.L., 6-INCH, 10 LB., CORDITE SIZE, 20,
CONVERTED MARKS IV AND V. (Half-Charge.)

These cartridges are similar in construction to the 10 lb. cordite cartridge (Plate XII). The Mark IV are converted from R.M.L. 12.5-inch 42½ lb. cartridges, and Mark V from 14 lb. 12 oz. cartridges.

CARTRIDGE, B.L., 6-INCH, GUN, 22 LB., E.X.E., LARGE PRISMS,
MARK I. (Half-Charge.)

For Paper Shot.

This cartridge is made of No. 3 silk cloth, hooped with seven silk braids, and a hole 2.5 inches in diameter, covered with silk netting and shalloon (the latter being removed before loading by a loop attached for that purpose) in the top and bottom.

It is made up in 16 tiers, 15 or 14 prisms each, and one of 11 prisms or such number as will bring the cartridge up to 22 lb.

Packed 5 (standing) in a whole metal-lined powder case.

† R.F.G.² in early manufacture.

CARTRIDGE, B.L., 6-INCH, GUN, 7 LB., BLANK, L.G., MARK I.

This cartridge is used for saluting and exercise. It is made of No. 1 class silk cloth, 7 lb. blank L.G. powder, hooped with three silk braids, and choked with silk twist.

Packed 15 in a whole metal-lined powder case.

CARTRIDGE, DRILL, B.L., 6-INCH, 20 LB. OR 23 LB., MARK I.

This drill cartridge represents the service full charge cartridge. It is of elm, weighted with lead, and covered with raw hide, with loops forming a handle at each end.

CARTRIDGE, AIMING RIFLE, 1-INCH ELECTRIC.

These cartridges are for use with the rifle aiming 1-in. Elswick "B."

The Mark V M consists of a solid drawn brass case, with a hole in the base tapped to receive the primer. The charge consists of 400 grains of R.F.G.² powder.

The Mark I primer consists of a brass tube with an enlarged head threaded to screw into the case. The tube is bored out, the metal being thinned at the front end.

Fitting in the tube is a brass contact pin, which is insulated with ebonite plugs. An iridio-platinum wire bridge (resistance 1 to 1.5 ohms) is soldered with pure tin to the point of the contact pin and front edge of the body, the bridge being surrounded with guncotton dust; the front end of the primer is closed with a card wad shellaced in. Two slots are cut in the head for the "key inserting and removing primer."

The bullet is made of an alloy of 12 parts lead and 1 part tin, and weighs about 9 oz. 408 grains; it has three cannellures round it filled with beeswax and the base is hollowed out.

The Mark IV M cartridge differs principally from the above in the primer which is pressed instead of being screwed in.

The Mark IV K N cartridge differs from Mark IV M in the primer only, which is of different dimensions and internal arrangements.

Packed 96 in a "Box, ammunition S.A.G.S." in bundles of 12.

CARTRIDGE, AIMING RIFLE, 1-INCH ELECTRIC, BLANK, MARK I.

This cartridge consists of the service charge and Mark IV Morris pattern case and primer, the charge being covered by two asbestos discs, which are coated with Pettman cement on the top and edges.

The mouth of the case is turned in.

Packed 12 in a bundle, 8 bundles in a box.

KEY, INSERTING AND REMOVING, PRIMER, CARTRIDGE, AIMING RIFLE, 1-INCH ELECTRIC, MARK I.

The key is of steel and is for use in inserting and removing the primer of the Mark V M electric cartridge.

SHELL, B.L. ARMOUR PIERCING, WITH CAP, 6 INCH. GUN, M^cV.

SCALE = $\frac{1}{2}$

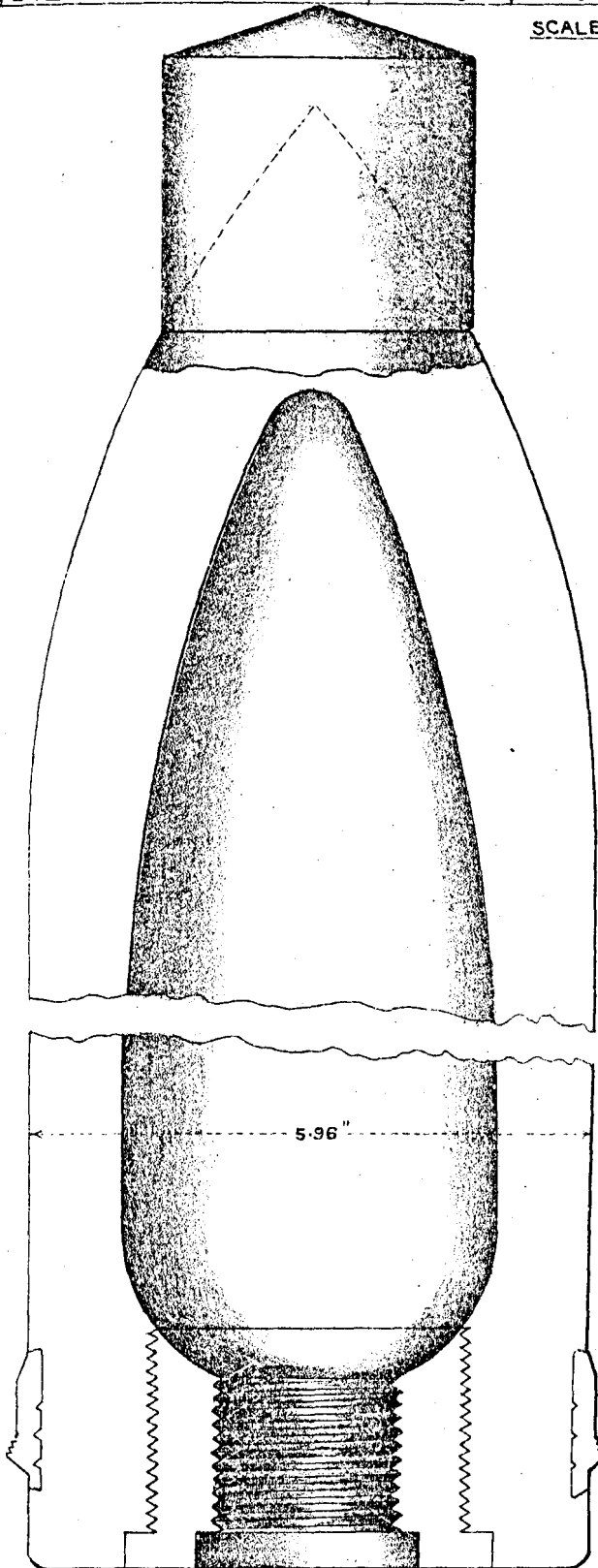

SHELL, B.L.Q.F. OR Q.F.C. ARMOUR PIERCING, 6 INCH, GUN M^KIII.

SCALE = 1/3.

LENGTH LEFT TO CONTRACTOR.

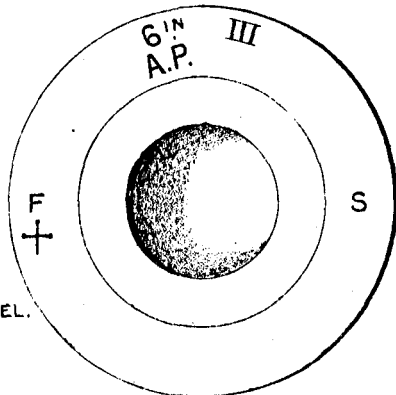
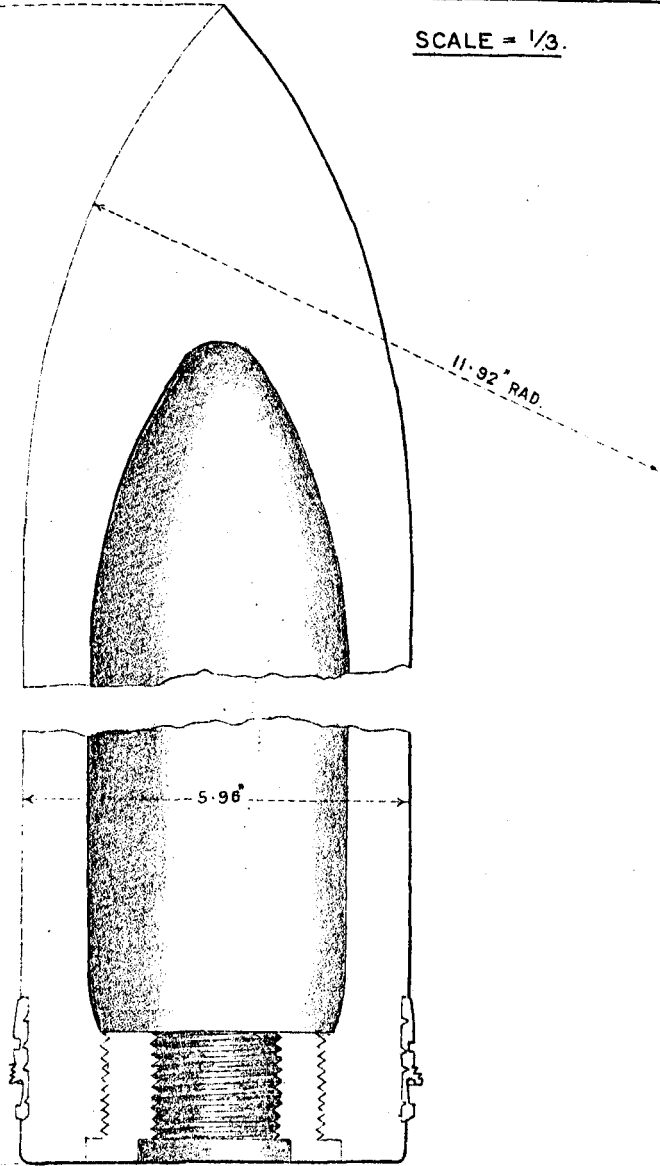

+ OR C' IF OF CAST STEEL.

PLAN OF BASE.

SHELL, B.L., Q.F., OR Q.F.C., COMMON LYDDITE, 6 INCH, M^K II

— SCALE = $\frac{1}{3}$ —

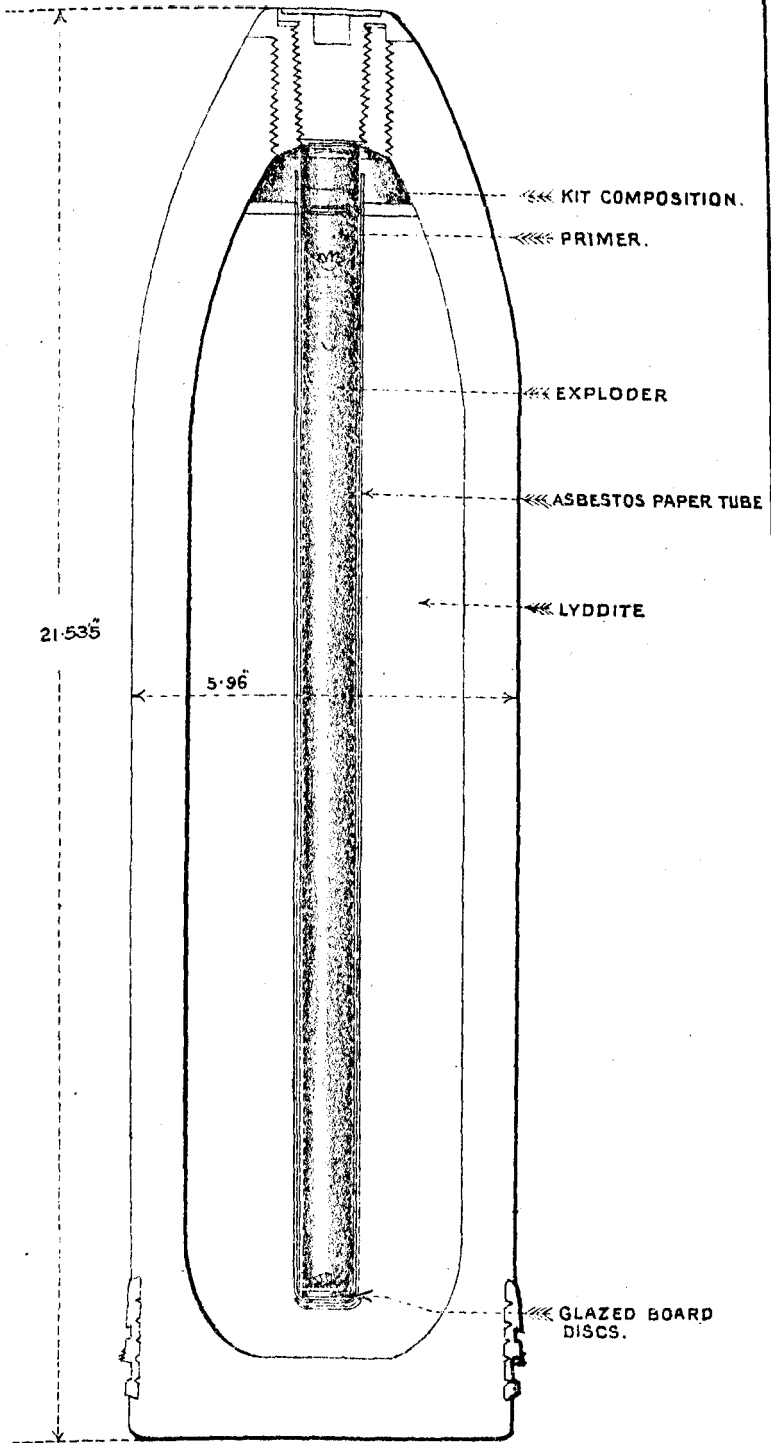

SHELL, B.L. ARMOUR-PIERCING, WITH CAP, 6-INCH.

(Plate XIII.)

Mark V shell is of forged or cast steel, with a hardened pointed head, which is struck with a radius of two diameters. A cap of mild steel is fixed over the point.

The total length of the shell is left to the manufacturer; the base is closed with a steel bush screwed in and tapped to take the "Fuze percussion, base large No. 15."

An undercut groove is turned in the body near the base, into which is pressed a cupro-nickel band to impart rotation to the projectile. In the groove are formed three waved ribs to prevent the band turning on the shell.

The inside of the shell is varnished, and the bursting charge of 2lb. 9oz. blank L.G. powder is contained in a lasting cloth bag.

SHELL, B.L., Q.F. OR Q.F.C. ARMOUR-PIERCING, 6-INCH.

(Plate XIV.)

Mark III shell is of forged or cast steel with a hardened pointed head, which is struck with a radius of two diameters. The total length of the shell is left to the manufacturer. The base is closed with a steel bush screwed in and tapped to take the "Fuze percussion, base, large, No. 11."

An undercut groove is turned in the body near the base, into which is pressed a copper gascheck driving band to impart rotation to the shell; four waved ribs are formed in the groove to prevent the band turning on the shell.

The driving band has one cannellure, and the front slope of the gascheck portion serrated or roughened to grip the bore when the shell is rammed home.

The inside of the shell is lacquered, and the bursting charge of 5lb. 8oz. P. and F.G. powder is contained in a dowlas bag. In shells filled since 1906 the bags burster are of lasting cloth, and any of the following powders may be used:—Blank L.G., R.L.G.⁴, L.G., R.L.G. or R.L.G.².

Mark II shell differs from the Mark III in having five straight instead of waved ribs in the groove for driving band; chisel cuts across the ribs prevent the band from turning.

SHELL, B.L., Q.F. OR Q.F.C. LYDDITE, COMMON, 6-INCH.

Mark VI shell is of forged steel with a solid base; the head is struck with a radius of two diameters, the point being truncated and fitted with a gunmetal bush which is tapped to the G.S. fuze-hole gauge.

The driving-band is the same as that described for the Mark III Armour-Piercing shell.

The interior of the shell is varnished and nearly filled with lyddite.

Lyddite shell are painted yellow all over, and are issued filled, no preparation being required before loading them in the gun other than fuzing.

Mark IV differs from Mark VI in not having a steel plate disc and in being slightly heavier.

Mark III shell differs from the Mark IV in having five straight instead of waved ribs.

Mark II differs from the Mark III in having thinner walls and consequently a larger bursting charge.

Mark I differs from the Mark II in the groove for driving-band not being undercut.

Marks I to III shells, which have been fitted in the base with a steel plate disc, will have a star added to the numeral, Mark IV will have two stars added.

For further details. See "Treatise on Ammunition."

SHELL, B.L., Q.F. OR Q.F.C. SHRAPNEL, 6-INCH.

(Plate XVI.)

Mark IX shell consists of a cast steel body with a solid base and a steel head.

The head, which is fitted with a metal fuze socket screwed to the G.S. gauge, is secured to the body by screws and twisting pins. The interior of the head is fitted with a wood block bored to take a tin socket, the top of which fits on the base of the fuze socket; at metal socket is soldered to the lower end of the tin socket to take a shrapnel primer.

The base of the interior of the body is recessed to take a tin cup containing a bursting charge of $10\frac{1}{2}$ oz. of R.F.G.² powder.

The shell is lined with brown paper and contains about 453 balls (14 per lb.) supported by a steel disc placed over the tin cup.

A metal central tube, which is screwed into the primer socket at the upper end and into the steel disc at the lower, conveys the flash to the bursting charge.

An undercut groove is turned on the outside of the shell .77-inch from the base, and is fitted with a copper gascheck driving-band with one cannellure. The groove has four waved ribs to prevent the band from turning on the shell.

Mark VIII differs from the Mark IX in the groove for driving-band having five straight ribs, the latter having chisel cuts across them to prevent the band turning on the shell. When shells are rebanded, waved ribs will be formed in the groove and a star added to the numeral.

Mark VII differs from Mark VIII in having thinner walls (.55-inch) and in containing 518 balls (14 per lb.). It is also .5-inch longer (18.925-inches.). When shell are rebanded, waved ribs will be formed in the groove and a star added to the numeral.

Mark VI differs from the Mark VII in the groove for driving-band not being undercut. When shells are rebanded the groove will be undercut and waved ribs formed, two stars being added to the numeral. Shells which have only had the groove undercut have one star added to the numeral.

Mark V differs from Mark VI in having a driving-band with the front slope slightly grooved and two undercut cannellures. Shells rebanded with the gascheck band described for the Mark IX have a star added to the numeral, but if the groove is also undercut and waved ribs formed, three stars are added to the numeral.

SHELL, B.L., Q.F. OR Q.F.C. SHRAPNEL, 6-INCH, CAST STEEL, MARK IX

SCALE = $\frac{1}{3}$.

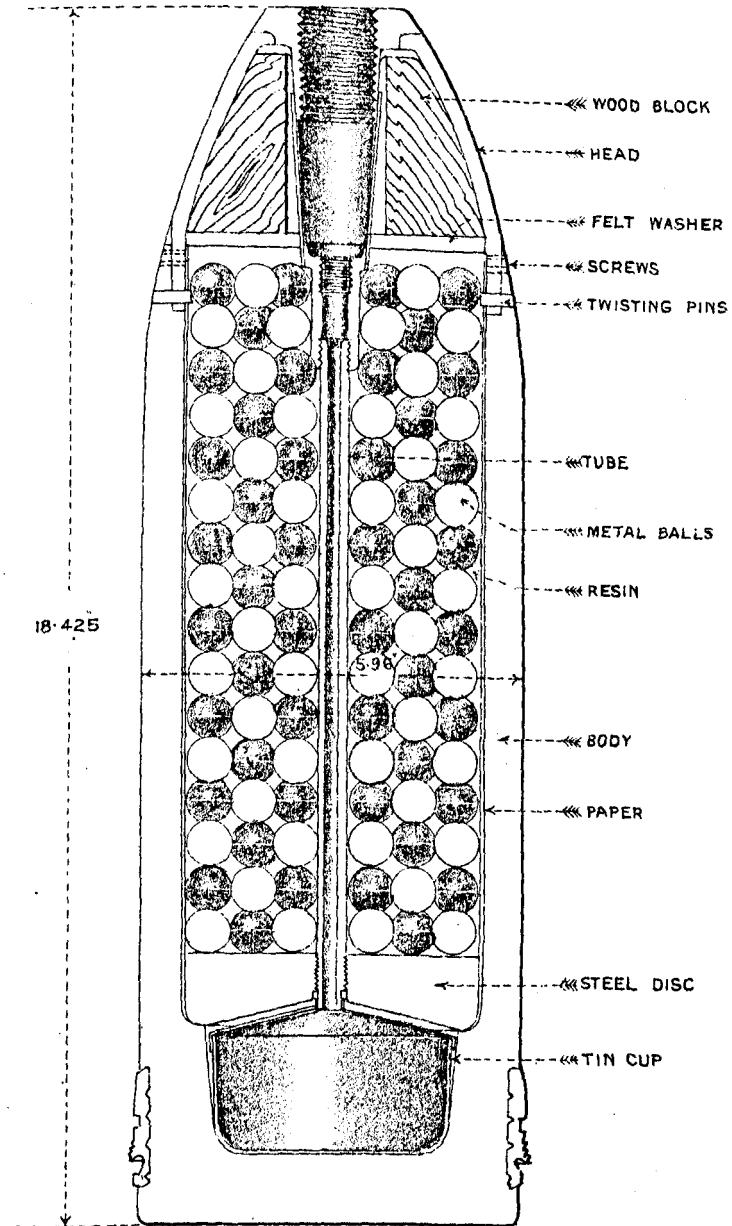

SHOT, PRACTICE, B.L., Q.F. OR Q.F.C.
6-INCH. GUN, MARK I.

SCALE = 1/3.

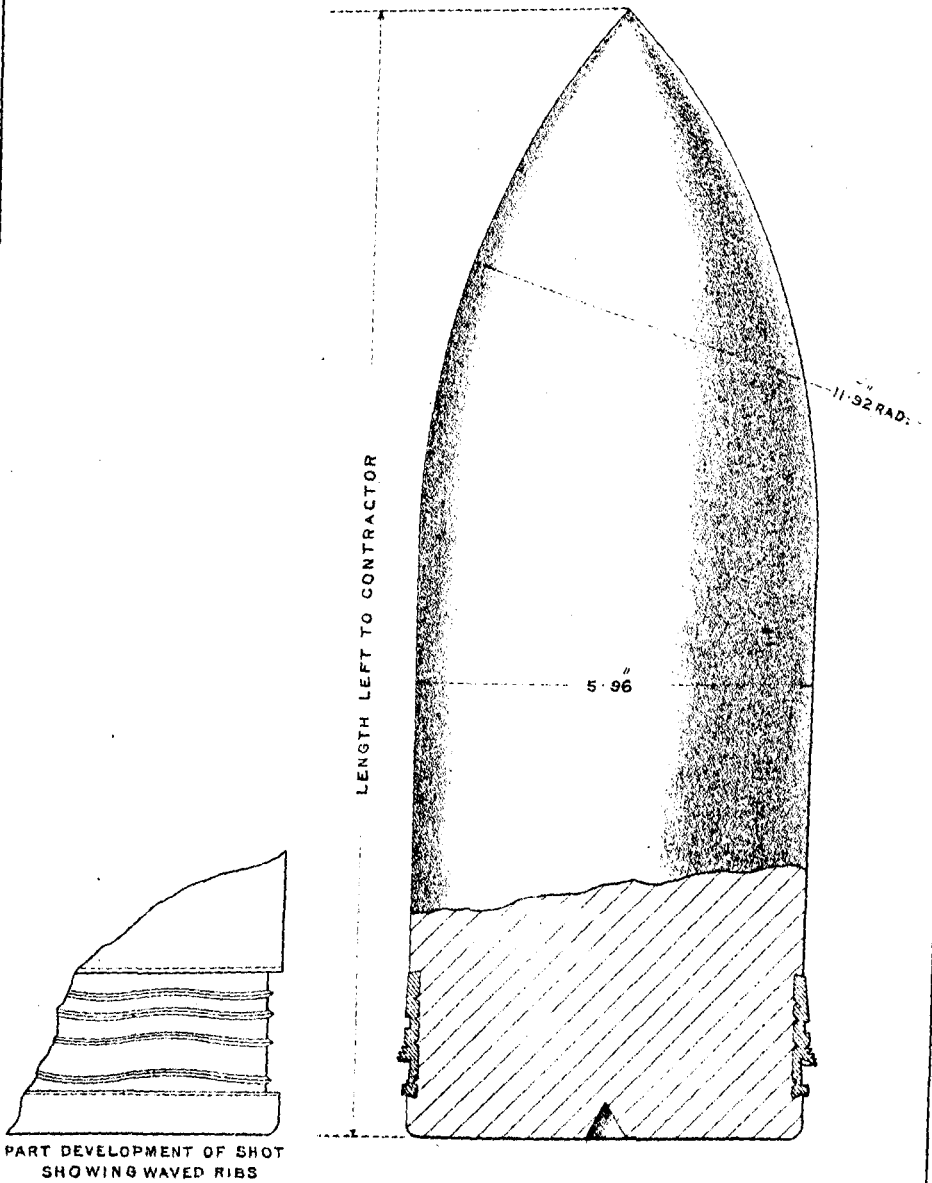

Mark IV has thinner walls (.5-inch), and 536 balls (14 per lb.), otherwise it is the same as Mark V. Shells rebanded with the gascheck band described for the Mark IX have a star added to the numeral, but if the groove is also undercut, and waved ribs formed, three stars are added to the numeral.

SHOT, PAPER, EMPTY, B.L., B.L.C. OR Q.F., 6-INCH,

MARK IV.

Mark IV consists of a pressed wood pulp cylinder painted black, and having a filling hole in the base, closed with a bung. When required for use the shot is brought up to weight by filling with a proportion of small shot and sawdust. The previous marks differ principally in being made of brown paper or papier-mâché.

Paper shot are stencilled "Not to be fired with cordite." As they break up on firing, the small shot travel but a short distance (about 200 yards), while the effect, for purposes of testing recoil, &c., is practically the same as that obtained with the service projectile. They will, therefore, be issued for use in time of peace, where the use of the service projectile would be dangerous or inconvenient.

There will, no doubt, be emplacements from which, owing to the close vicinity of houses, it may be undesirable to use these shots in the normal line of fire. In these cases it will be often found possible, owing to the very short range of the paper shot, to find sufficient space to the right or left of the regular range to carry out such test practice as may be required.

SHOT, PRACTICE, B.L., Q.F. OR Q.F.C., 6-INCH.

(Plate XVII.)

Mark I shot is made of cast iron with a pointed head struck with a radius of 2 diameters. The total length of the shot is left to the manufacturer. The driving band is identical with that described for the Mark III Armour-Piercing shell.

The following projectiles are also used for practice purposes:—

SHELL, B.L., Q.F. OR Q.F.C., COMMON-POINTED 6-INCH.

These shell are made of cast steel.

A hole is bored in the base to take the "Fuze percussion, base, large No. 11."

The bursting charge consists of 9lb. 4oz. P. and F.G. powder.

SHELL, B.L., Q.F. OR Q.F.C. COMMON, 6-INCH.

Marks III and IX are made of iron and have a bursting charge of 7lb. 4oz. P. and F.G.

Marks V and VI are made of cast steel and have a bursting charge of 8lb. 14oz. and 9lb. 13oz. P. and F.G. respectively.

The shells are truncated and fitted with a G.S. fuzehole socket to take the "Fuze, D.A. with cap No 1" for guns on land fronts and "Fuze, D.A. with plug No. 3 for guns on sea fronts."

SHELL, B.L. OR Q.F. DRILL 6-INCH GUN.

Mark V drill shell is of cast iron, with two gunmetal bands to prevent injury to the rifling of the gun. The nose is bushed with a gunmetal socket tapped to G.S. gauge and the base fitted with a large hollowed and flanged gunmetal plug having a crossbar to which the No. 1 extractor may be hooked for extracting the shell from the gun.

A groove is turned between the gunmetal plug and the body of the shell which is filled with spun yarn wound round the shell to prevent the shell jamming in the gun.

Previous marks of drill shells have been altered to approximate to the Mark V, a star being added to the numerals.

AUGMENTING STRIPS.

Projectiles not fitted with gas-check driving-band may be fired with cordite charges at practice, provided that an augmenting strip is used.

The augmenting strip should be fitted in the rear cannellure of the driving-band.

In the case of worn guns an additional augmenting strip will be fitted in the front cannellure when required.

The augmenting strips are of copper, of even section throughout and grooved on one side.

Method of insertion.—The cannellure in the driving-band is to be undercut all round on both sides by means of a special chisel supplied for that purpose. (Cannellures are undercut in late manufacture and the driving-band marked "U.") The augmenting strip is inserted in the cannellure grooved side of the strip inwards, and lightly hammered until the tongues, formed by the groove in the inner side of the strip, are dovetailed into the undercuts of the cannellure.

For instructions respecting the preparation, &c., of projectiles, see "Regulations for Magazines and Care of War Matériel."

FUZE, PERCUSSION, BASE, LARGE, BRONZE, No. 15.

(Plate XVIII.)

This fuze is for use with armour piercing shells *with cap*.

Mark III consists of the following parts:—Aluminium bronze body, detonator pellet, centrifugal bolt, copper pressure plate, perforated steel plug, locking pellet, small retaining bolt, retaining bolt for pea ball, pea ball, detonator plug, detonator, screwed cap with needle, phosphor-bronze spring, two brass springs, four screwed plugs for body, set screw, and screwed pin.

FUZE, PERCUSSION, BASE, LARGE, N° II, MARK V: METAL.
FUZE, PERCUSSION, BASE, LARGE, BRONZE, N° 15, MARK III.

SCALE = 1/4.

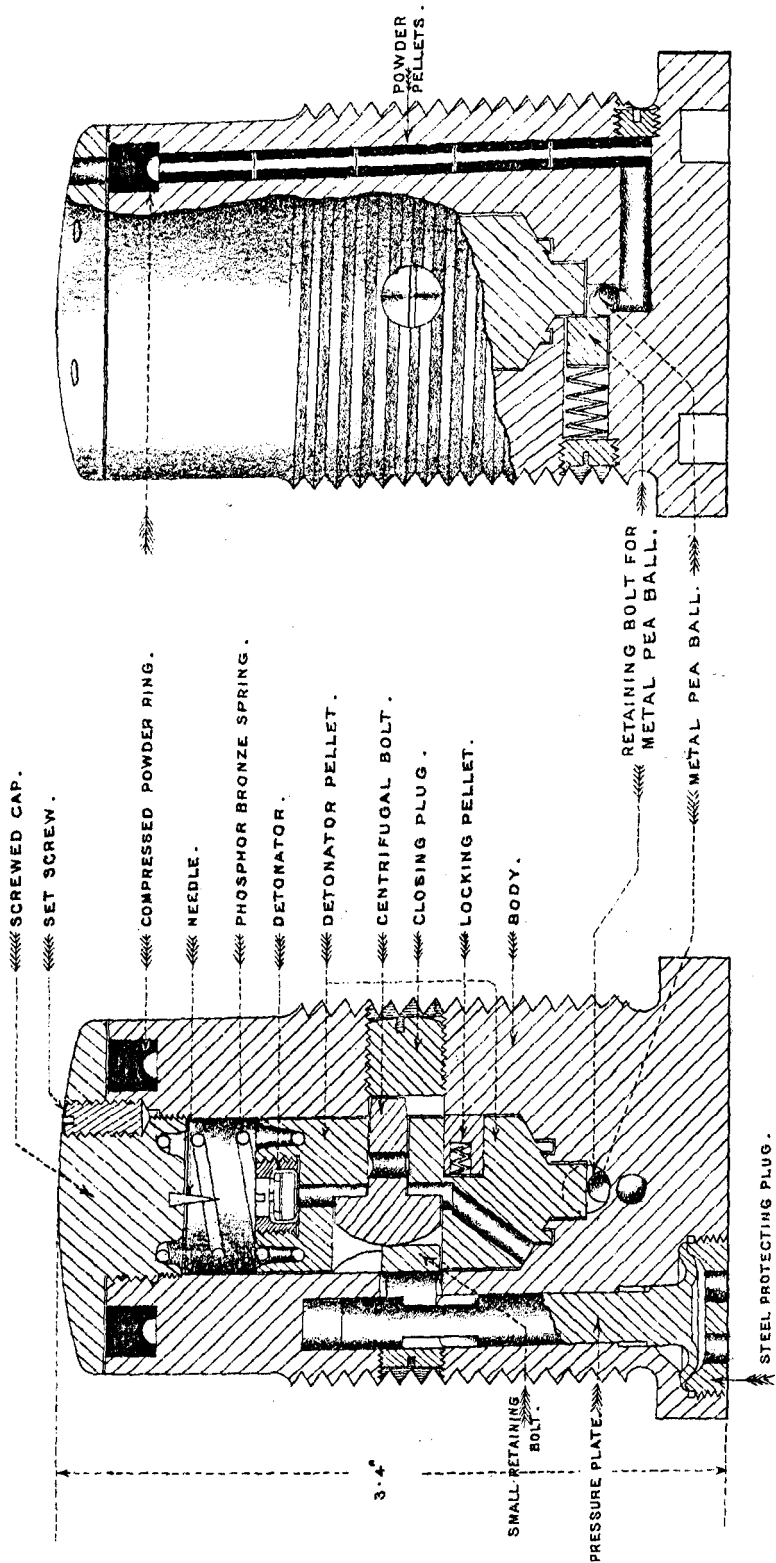

The body is turned and screwed on the exterior to suit the shell; the interior is bored out and screwed, the bottom of the bore being coned and recessed for the detonator pellet. A hole is bored through the side of the body to receive the small end of the centrifugal bolt, and closed by a screwed plug; a hole is also bored through the opposite side of the body to receive the small retaining bolt and closed by the screwed plug. A third hole is bored and screwed at an angle of 45° to the first hole, to receive the screwed pin for detonator pellet. Further holes are bored, one to receive the retaining bolt for pea ball, and two others longitudinally for the channel for powder pellets, and pressure plate; a hole is also bored from the powder pellet channel to the centre of the body. The top of the body has a circular recess for a compressed powder ring and two elongated holes are cut in the base of the body for screwing the fuze into the shell.

The interior of the detonator pellet is bored and screwed at the top to receive a detonator plug, and a flash hole is bored through. A hole is bored at right angles to the axis for the centrifugal bolt, and further holes for the brass pin of the centrifugal bolt and locking pellet. The exterior of the pellet at the top is recessed to form a seating for the spring, and the bottom is reduced in diameter, forming a cone and stem, to suit the body of the fuze. A slot in the pellet engaging with a pin screwed into the body of the fuze prevents the pellet turning.

The pressure plate is cupped, having a lip round the edge to form a gascheck. A portion of the stem is reduced in diameter to enter slot in the small retaining bolt.

The steel plug is perforated with four holes, and is secured in the recess in the base below the pressure plate by centre punch dabs. The underside is coated with rubber solution.

The detonator contains about three grains of composition.

The screwed cap has a curved top and the lower part reduced in diameter to suit the top of body. The bottom is reduced in diameter to accommodate the spring, and has a steel needle firmly embedded in, and projecting beyond it. Six holes are bored through the flange of cap and a hole bored and screwed for the set screw; the latter for fixing the cap.

The centrifugal bolt is fitted with a brass pin, which engages in a hole in the detonator pellet to prevent the bolt turning. A flash hole is bored through the stem of the bolt.

The small retaining bolt prevents any movement of the centrifugal bolt.

The pea ball seals the channel in the body containing the powder pellets, and is held in position by its retaining bolt.

Weight of fuze, 2lb. 10ozs.

The fuzes are issued, wrapped in brown paper, one in a tin cylinder.

Action.—On discharge the pressure of the gas crushes in the pressure plate causing the spindle to release the small retaining bolt, and consequently the centrifugal bolt; the rotation of the shell causes the latter bolt to spin out, leaving the detonator pellet free. On impact the detonator pellet moves forward on to the needle and is locked by the locking bolt; the flash from the detonator passes through the central channel of the pellet and

hole in the centrifugal bolt and so to the channel containing the powder pellets, the pea ball retaining bolt and ball having previously spun out owing to the rotation of the shell. The powder pellets burn up through the body to the compressed powder ring in the top when the flash passes through the holes in the cap and into the shell.

Marks I and II fuzes are similar internally to the "Fuze, percussion, base, large, No. 11, Mark IV" (*Plate XIX*), except that they are made of bronze. Mark II, however, has a cupped pressure plate and steel plug (with four holes only), and is slightly longer.

FUZE, PERCUSSION, BASE, LARGE, No. 11.

This fuze is for use with common-pointed and uncapped armour-piercing shell.

Mark V fuze differs from the "Fuze, percussion, base, large, bronze, No. 15, Mark III" (*Plate XVIII*), already described, in being made of metal instead of bronze.

Mark IV (*Plate XIX*) consists of the following parts:—Body, needle pellet, centrifugal bolt, pressure plate with spindle and nut, steel protecting plug, screwed cap with detonator and magazine, phosphor-bronze spring, brass spiral springs and four screws.

The body is turned and screwed on the exterior to suit the shell; the interior is bored out to receive the needle pellet and threaded at the top to receive the screwed cap; a hole is bored in the base for the spindle of the pressure plate to pass through; a recess is also formed in the base to take the pressure plate and protecting plug. A hole is bored through the side of the body and is closed with a brass screw plug with the end reduced to form a seating for a brass spiral spring which keeps the centrifugal bolt in position; a recess is also made in the opposite side of the body in which the small end of the centrifugal bolt engages. Two elongated holes are made in the base for screwing the fuze into the shell.

The needle pellet is cylindrical in form and rests on the bottom of the recess in the body; it is reduced at the top end to form a seating for the spiral spring which prevents the pellet working forward during flight. A hole is bored at right angles to the axis to take the centrifugal bolt; a hole is also bored longitudinally to take the spindle and nut of the pressure plate, and the upper part is threaded to receive the needle plug. The pellet is prevented from turning by a slot in the side engaging with a pin projecting from the side of the body.

The centrifugal bolt is cylindrical in form, and fits in the hole in the needle pellet; one end is reduced in diameter to fit in the hole inside the body made to receive it. An elongated hole is bored through it, and the upper surface on one side is recessed for the nut on the pressure plate spindle to engage in, thus locking the bolt till the pressure plate is crushed in.

The pressure plate has a boss on one side, into which the spindle is screwed; it fits in an undercut recess in the base of the fuze.

The protecting plug is perforated with eight holes and fits in an undercut recess, over the pressure plate, in the base of the fuze. It is intended to protect the pressure plate from accidental blows.

FUZE, PERCUSSION, BASE, LARGE, N° II, MARK IV.

SCALE = 1/1.

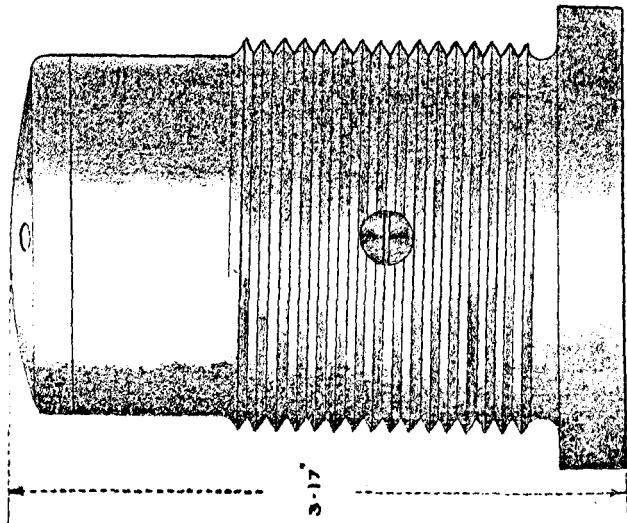
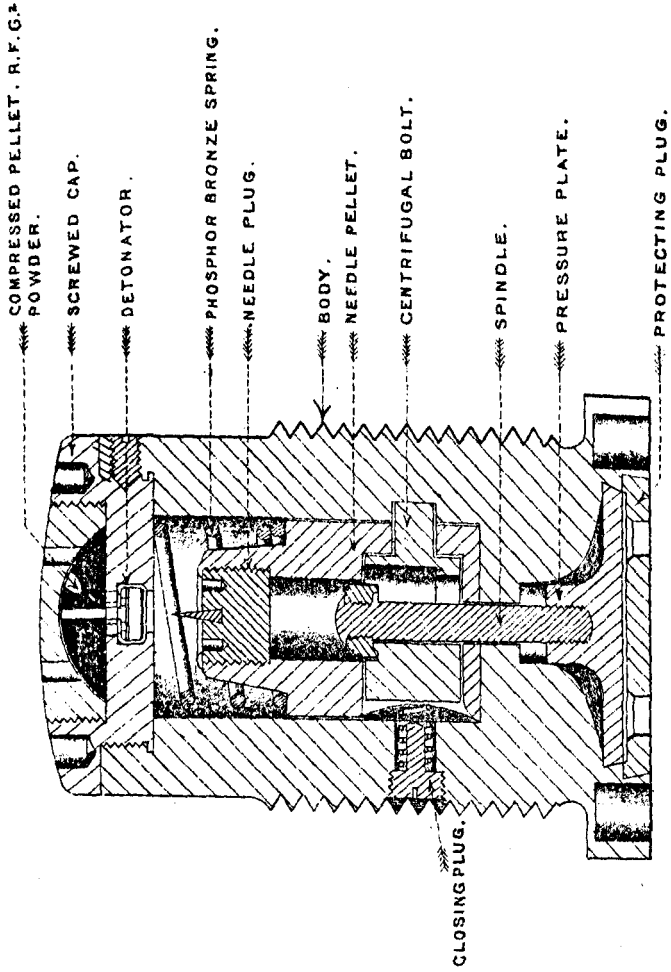

FUZE, PERCUSSION, DIRECT ACTION, IMPACT, N^o 13, MARK IV.

SCALE $\frac{1}{1}$.

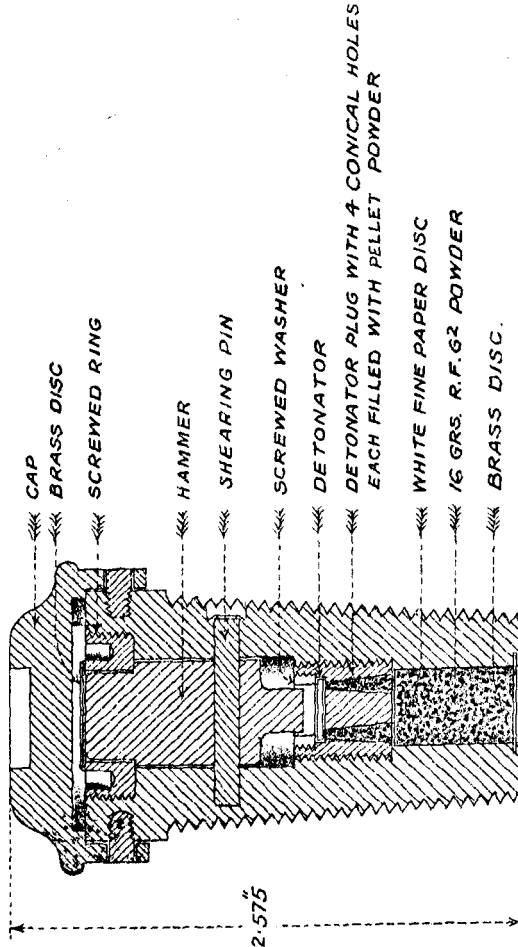
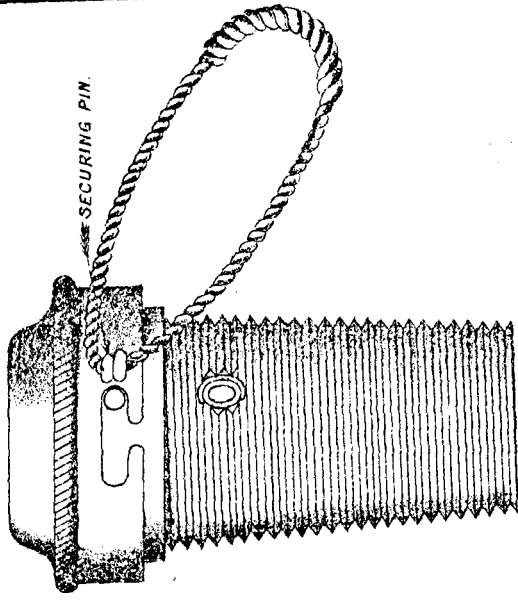

- CAP
- BRASS DISC
- SCREWED RING
- HAMMER
- SHEARING PIN
- SCREWED WASHER
- DETONATOR
- DETONATOR PLUG WITH 4 CONICAL HOLES
EACH FILLED WITH PELLET POWDER
- WHITE FINE PAPER DISC
- 16 GRs. R.F.G. POWDER
- BRASS DISC.

2.575

The screwed cap is in two parts screwed together, the two parts forming a magazine containing a perforated R.F.G.² powder pellet. A recess is made in the underside to receive the detonator which is spun in, and six fire holes are bored to convey the flash to the powder. A locking screw through the body of the fuze prevents the cap from unscrewing.

Weight of fuze 2lb. 8oz.

The fuzes are issued, wrapped in brown paper, one in a tin cylinder.

Action.—On discharge, the gas acting through the holes in the protecting plate causes the pressure plate to be crushed in, carrying forward the spindle and nut, thus releasing the centrifugal bolt. The rotation of the shell causes the centrifugal bolt to fly outwards, leaving the needle pellet free to move forward; on impact or graze the spiral spring is compressed, the needle fires the detonator and ignites the powder in the magazine, the flash of which passes through the holes in the cap and into the shell.

Mark III differs in having less protrusion of the centrifugal bolt into the body.

Mark II differs from Mark III in having no steel protecting plate.

Mark I differs from Mark II in the form of recess for the pressure plate, the shoulder of which is not so much cut away. The fuze is less sensitive since the pressure plate offers greater resistance.

Fuzes of early marks (except Mark II) when converted to the Mark IV pattern will have a star added to the numeral.

FUZE, PERCUSSION, DIRECT ACTION, IMPACT No. 19.

(Plate XX.)

Mark IV fuze, which is of gunmetal, is screwed externally below the head to the G.S. gauge.

The head is turned and has a projection on each side to engage the cap with which the fuze is furnished.

The body is bored throughout its length and contains a hammer, detonator plug containing detonator, and 16 grains of R.F.G.² powder.

The hammer is held in suspension over the detonator by a shearing pin, which passes through the side of the fuze and is spun in.

The detonator plug has a recess in the top to take the detonator and has also four conical holes filled with pellet powder.

The detonator is secured in the plug by a brass screwed washer. The fuze is closed at the head by a screwed ring with a brass disc spun in, and at the base with a brass disc spun in.

The cap has a T-shaped cut in each side of its rim to lock on the projections on the body, where it is further secured by a securing pin. The cap has also a square keyhole in the top to take the fuze key for screwing the fuze into the shell.

The fuze requires no preparation beyond removing the securing pin and cap at the moment of loading.

Action.—On impact the hammer is driven in, shearing the steel pin and igniting the detonator, the flash passing through the detonator plug into the magazine.

Earlier marks of this fuze have been altered to conform to the Mark IV, a star being added to the numeral.

Weight of fuze without cap, 10oz.

” ” cap, 3oz.

These fuzes are issued one in a tin cylinder.

FUZE, TIME AND PERCUSSION, No. 64, MARK I.

This fuze is of metal, screwed to suit the G.S. fuze hole. It has two composition rings, the lower one being milled to facilitate setting.

To set the time arrangement, the cap is loosened with the fuze key provided, and the ring moved round until the required graduation is opposite the pointer, the cap is then tightened, great care being taken to screw it down as tightly as possible.

If the fuze is required to act as percussion, the P pin only should be removed, otherwise both pins should be removed. This, however, should not be done until the moment of loading.

Weight about 1lb. 13oz.

The fuzes are issued one in a tin cylinder, 25 cylinders in a wood case.

FUZES, DRILL.

The drill fuzes resemble, generally, the service fuzes which they represent, and in some cases burnt-out service time and percussion fuzes are used for this purpose.

To facilitate identification, the drill fuzes are stamped “DRILL” and bronzed.

TUBES, VENT-SEALING, ELECTRIC, WIRELESS, P.

(Plate XXI.)

Mark V consists of a body, ebonite insulator for head, brass pole, brass nut, socket, ebonite cylinder, copper gascheck, brass gascheck, ebonite nut, crown metal contact piece, iridio-platinum wire bridge, brass washer, ebonite washer, 2 mica washers, asbestos ring, paper and glazed board discs, and cork plug.

The body is of brass with a screwed recess in the head to receive an ebonite insulator into which fits a crown metal contact piece, the latter being connected with the interior of the tube by a brass pole; the pole is insulated from the body of the tube by ebonite. The body of the tube is also bored out on the interior to take a brass socket.

To effect the internal gas sealing, the brass pole has a shoulder formed at the centre of it over which passes a copper gascheck, which is insulated from the pole by an ebonite cylinder. An asbestos ring is pressed into the copper gascheck and held by a brass gascheck and an ebonite nut screwed on to the brass pole.

At the lower end of the copper gascheck a projection is made and bent inwards; the bridge (iridio-platinum Z13 wire) being formed from it to the brass pole. The bridge is surrounded by 2 to 3 grains of composition priming, under which is placed a glazed board and paper disc.

TUBE, VENT SEALING, ELECTRIC, WIRELESS, P. MARK IV.

SCALE = $\frac{1}{1}$.

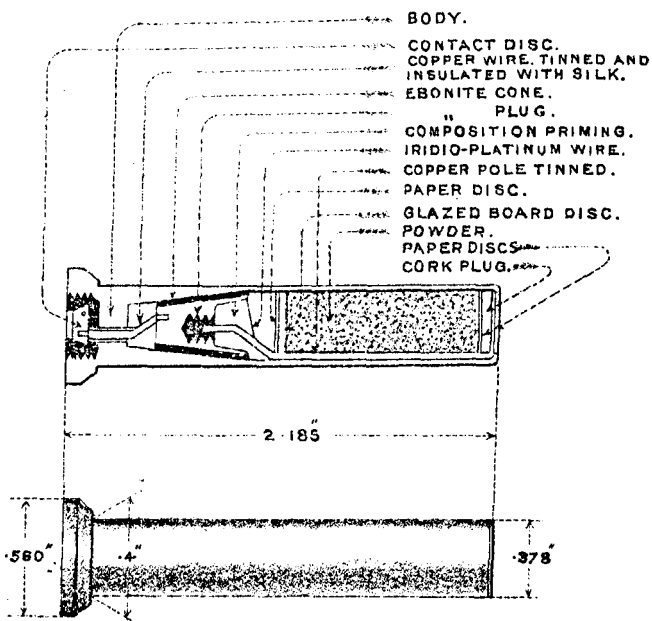

TUBE, VENT SEALING, ELECTRIC, WIRELESS, P. MARK V.

SCALE = $\frac{1}{1}$.

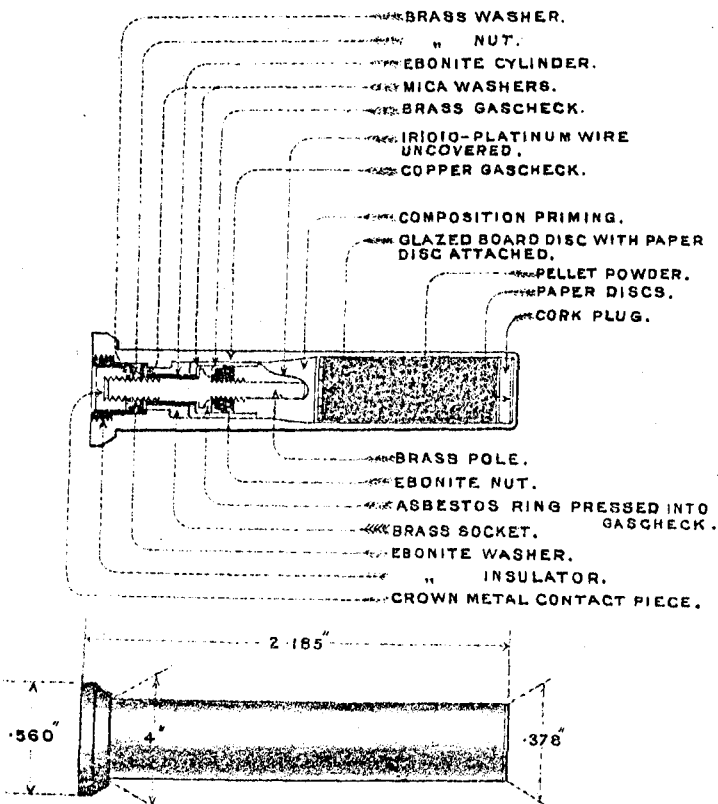

The tube is filled with about 23 grains of pellet powder, the end of the tube being closed by discs of paper and a cork plug, and further secured by the end of the tube being burred over.

Action.—On contact being made the current passes through the striker, brass pole, bridge, copper gascheck and the body of the tube. The bridge becomes incandescent, which fires the priming and powder; the copper gascheck between the brass socket in the body and the shoulder on the brass pole prevents the escape of gas through the head.

Packed. 10 in a tin box.

Mark IV consists of a body, conical brass plug, copper pole, cork plug, ebonite cup, ebonite plug, hollow ebonite cone, insulated copper wire, glazed board and paper discs, and an iridio-platinum wire bridge.

The body is made of brass, with a recess in the head to receive an ebonite cup which is screwed into the head of the tube, and into which fits a pure tin contact disc, secured by an undercut groove in the ebonite, and connected by an insulated copper wire with the interior of the tube; a hole is bored through the head of the tube for the copper wire to pass through. The lower end of the insulated wire is attached to the brass conical plug, which is insulated from the body of the tube by the hollow ebonite cone. The large end of the brass cone is cupped out to form a gas check, and has a centre hole bored and screwed to receive an ebonite plug. Into this ebonite plug is fixed a copper pole, which consists of a copper wire, coated with pure tin, one end fitting into the ebonite plug, the other being secured to the side of the tube.

The copper pole and conical brass plug are connected by a single bridge of iridio-platinum "wire, uncovered, Z13." The space round the bridge and pole is charged with 2 grains of composition priming, under which is placed a perforated glazed board disc with paper disc attached.

The tube is filled with pellet powder, and the end is closed by discs of paper and a cork plug shellaced in and further secured (in later manufacture) by the end of the tube being burred over.

Action.—On contact being made the current passes through the striker, contact disc, short wire, cone, bridge, long copper pole, and the body of the tube. The bridge becomes incandescent, which fires the priming and powder, the gas expands the cupped-out cone and prevents the escape of gas through the head.

Mark III tube differs from Mark IV by having a bridge of platinum silver, and only a paper disc intervening between the priming composition and the powder.

Mark II differs from Mark III in having a smaller contact disc, which in some of the earlier issues were made of solder instead of pure tin. *This mark is not to be used in adapters for service practice from Q.F. guns.*

Mark I differs from Mark II in having two bridges. In the majority of Mark I tubes also, the ebonite insulating plug is not screwed into the head. *This mark will be used up for drill and instructional purposes only.*

TUBES, VENT-SEALING, PERCUSSION.

(Plate XXII.)

Mark VII consists of a body, cap, cap-holder, striker brass washer, copper shearing wire, striker holder, two paper discs, and a cork plug.

The body is of brass; the head is bored centrally to receive the cap and striker, the front end of this recess is formed into a raised anvil, through which two fire channels are bored. The cap is held in position on the anvil by the cap-holder, and above the latter is screwed the striker holder, in which is secured the striker by a copper shearing wire, and by being riveted at its outer end to a brass washer.

The lower part of the tube is filled with 32 grains of pellet powder. The tube is closed with a paper disc and cork plug, which is coated with varnish, and further secured by the end of the tube being burred over.

Percussion V.S. tubes of present manufacture are blackened all over, and have four notches cut in the rim of the head to distinguish them from wireless electric tubes by sight or touch.

Action.—On firing the gun the point of the striker of the percussion lock drives the striker of the tube together with the cap on to the anvil, thus firing the tube.

Mark VI consists of a body, striker, detonator, detonator holder, two washers, shearing wire, two paper discs, and cork plug.

The body is of solid drawn brass; the head is bored centrally for the striker, detonator, and fire channel. The striker is of brass with a needle point, and a plain flange at its base under which is fitted a copper cup-shaped gascheck; it is held in position by a copper shearing wire passed through the tube and a brass washer in the recessed head of the tube. The detonator is fitted into the holder, and the latter is screwed into the body of the tube. Under the detonator holder is a copper washer, and a disc of fine white paper. The lower part of the tube is filled with pellet powder. The tube is closed with a paper disc, and cork plug which is coated with varnish, and further secured by the end of the tube being burred over.

Action.—On firing the gun, the point of the striker of the percussion lock drives the striker of the tube on to the detonator, thus firing the tube, the flash passing on to the charge.

Mark V tube differs from Mark VI in the form of the striker, which is without the cup-shaped gascheck, and the detonator which is held in position by a brass screwed collar. *This mark will be used up for drill and instructional purposes only.*

Mark IV.—This consists of a body, anvil, striker, brass washer, percussion cap, copper washer, two paper discs, and a cork plug. The body is made of brass, solid drawn; a hole is drilled through the head to receive the striker, which is secured in position by being riveted into the countersunk washer. The upper part of the chamber is screwed and fitted with an anvil, on which is placed the percussion cap, the upper surface of which is in contact with the striker; a small central and two diagonal fire-holes are drilled through the anvil. The remainder of the space in the tube is filled with pellet powder, and the bottom is closed with a paper disc, and cork plug coated with varnish.

TUBE, VENT SEALING, PERCUSSION, MARK VI.

SCALE - 1/1.

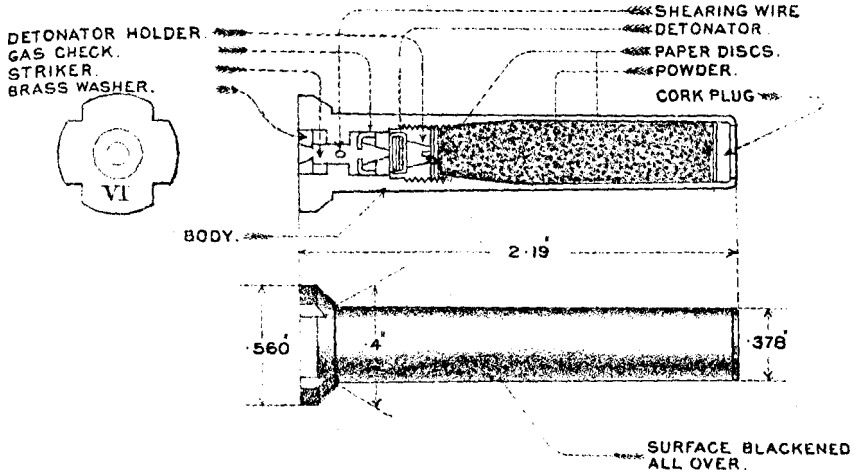

TUBE, VENT SEALING, PERCUSSION, MARK VII.

SCALE - 1/1.

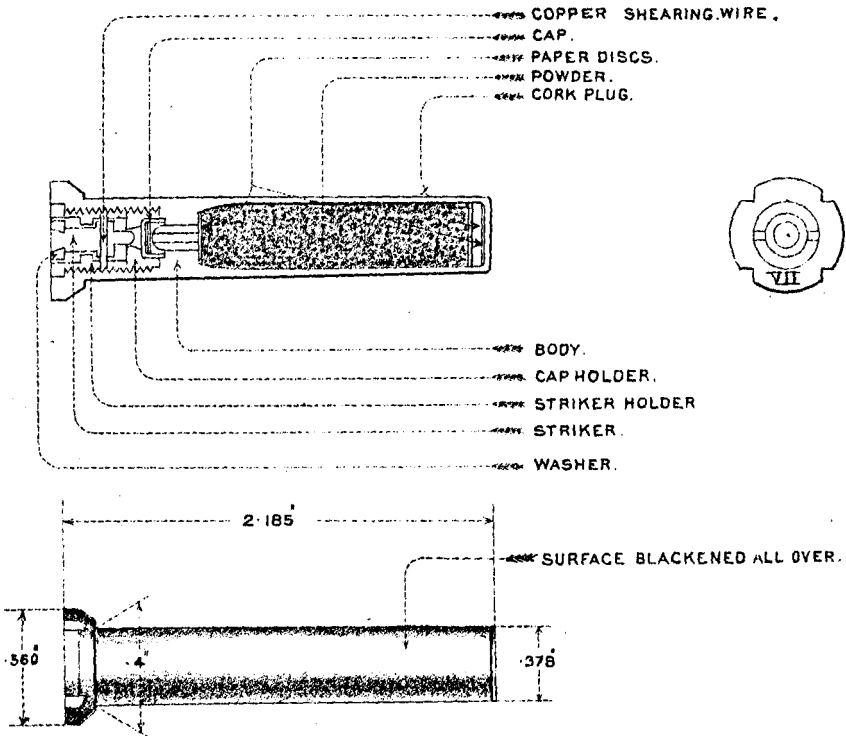

TUBE, VENT SEALING, PERCUSSION, DRILL, MARK II.

SCALE = 1/1.

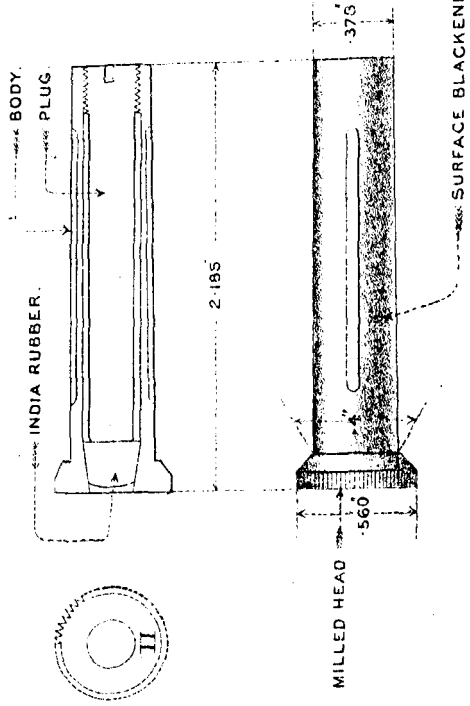

Action.—This is the same as Mark VI tube, except that the striker of the tube together with the percussion cap, is driven on to the anvil, thus firing the tube.

Mark III is the same as Mark IV, except that the bottom of the tube is closed with a paper disc and perforated brass ball embedded in sulphur and secured with shellac. *It must not be used unless the range is clear ; see also Notes below. This Mark will be used up for drill and instructional purposes.*

Mark II tube differs from Mark IV in not having the diagonal fire-holes in the anvil.

These tubes are packed 10 in a tin box.

Notes.

In the event of a tube failing to ignite a charge, care should be taken in extracting the fired tube not to stand directly in rear of the gun, as the gas generated will cause the tube to fly out with some violence when eased by the extractor.

Care must be taken to see that the range is clear when using vent-sealing tubes with ball (Mark III percussion), for clearing the vent or for any other purpose, as the brass ball is projected with considerable velocity by the powder in the tube.

TUBES, VENT-SEALING, PERCUSSION, DRILL.

(Plate XXIII.)

Mark II is of gunmetal, and of the same external dimensions as the service V.S. percussion tube ; the body is blackened all over, four longitudinal grooves are cut in the body, and the rim of the head is milled, to distinguish it by sight or touch from other tubes.

Internally it is bored out and fitted with a coned plug of rubber secured in position by a gunmetal plug screwed in the front end.

Mark I differs from Mark II in being much shorter, and in not being blackened, grooved or milled. *No more of this Mark will be made.*

DRILL.

The gun detachment consists of a Gun Captain, two Gun Layers, a Setter,* and 8 other gun numbers. It falls in and is told off in the usual manner.

AMMUNITION SUPPLY.

Cartridges are supplied from recesses (or depôts if required) in the emplacement, by hand to the gun platform. Supply may also be made to the level of the emplacement by lift.

Projectiles are supplied from recesses in the emplacement, and from depôts, which should be arranged round the emplacement floor under cover of the parapet. Supply may also be made to the level of the gun platform by lift.

The normal supply of ammunition will be from the recesses or depôts; in this case **6** and **8** working alternately supply **3** or **5** with cartridges, and **7** and **9** lift projectiles on to the gun platform. This supply must be made intelligently as the gun is traversed, from the most convenient recess or depôt.

When supply is from lifts, **6** and **8** will work in a similar manner, keeping **3** or **5** supplied by the shortest way; **3** and **5** pick up and load shells alternately, **7** and **9** go below to assist the ammunition detail.

Lids of cylinders will be removed at the foot of the cartridge lift before sending up, and cartridges will be supplied naked to **3** or **5**.

Empties will be stacked by **6** and **8** without obstructing the working numbers at the gun.

As the recesses only hold a limited number of rounds it will be advisable not to reduce the total for each gun below 12, and when this point has been reached, to change to lift supply.

In addition to the above detail, when guns are served by lifts direct from both shell and cartridge stores, 6 additional numbers will be required to supply and work the lift.

TO PREPARE FOR ACTION.

Gun Group Commander.

*"A Group,
Prepare for Action."*

Gun Captain.

*"A 1,
Prepare for Action."*

At this order stores are brought up as follows:—

Gun Captain.—Gauge protrusion striker.

Gun Layers.—Electric firing battery (if not on mounting), box of spare parts and tools, sights, and pistol grip.

* The Setter will be taken from the 50 % spare.

If necessary a second Setter may be taken to assist the Auto Layer at Case III.

2. Vent bit, Russian tallow, waste, tubes, spare leads, and tray stores complete†, for drill, a drill tube.

3. Lanyard.

4. Combined rammer and sponge, hook withdrawing guide bolt, bucket filled with water, and sponge cloth.

5. Assists the Gun Layers.

6 and 8. Keys of cartridges and shell recesses. For drill purposes a drill cartridge.

7 and 9. Brush; two keys, fuze, universal; two keys, base fuze and plug (when required), and grease box. For drill purposes a drill shell and shell extractor. Gun floor numbers knee caps.

The following group and battery stores will be brought up, and such others as are considered necessary locally:—

Battery Stores.

Bar Testing sight	1 per work
Buffers, syringe	1 „
Clinometers, large	1 „
Instruments, testing primary batteries or voltmeters	1 „

Group Stores.

Borers, tube chamber	{ Square end	1
	{ Pointed end	1
Brush, rammer and sponge	1 per gun	
Extractor tube special, Box Slide "A"	1 per 2 guns	
Hammers, claw	1	
Lock, E. & P. "F."	1 per 2 guns	
Pliers, side cutting, 8-inch	1	
Whistles	1	

The Gun Captain will satisfy himself that the buffer is properly connected up, not leaking at the glands, and contains the correct amount of oil; that the capsquares are properly secured, and that the lubricators on the top of the cradle are filled with oil. When the breech is opened he looks to see that the bore is clear. He superintends the firing of an electric and a percussion tube to test the firing arrangements. He receives reports, from the numbers responsible, of any irregularity or deficiency in connection with the different parts of the gun, mounting or stores.

The Gun Layers fix the sights in the cradle and see that they fit and work properly, and that the sight carrier or bracket is firmly attached to the mounting; test the sights and elevation indicator,

† Contents of Tray Stores:—

1 box grease, 3lb.
2 boxes tube, garrison.—(1 to hold spare parts).
1 piece of chalk.
1 lock, E. and P. "F."
1 box, slide "A."
1 oil can, No. 9.
1 rimer, vent, axial, short.
1 screwdriver, 4-inch.
1 " " No. 13.
1 McMahon spanner, 15-inch.
1 wrench, breech mechanism, No. 46.
1 " " " " 41.

place the pistol grip in position, examine the lock, gauge its protrusion,* and place it in position on the slide box in the vent, make the necessary connections, and test the firing circuit. They see that the elevating and traversing gears are oiled and in good working order. Uncover the dials and see that they are properly connected up.

2 places the oil can, Russian tallow and waste in a convenient position on the mounting, and his other stores handy for use, attaches the tube boxes to the mounting, placing some tubes in the tube box and the remainder in a convenient position for use. He places the vent bit in the clips on the right spring box.

3 removes the breech and muzzle covers and places lanyard handy for use.

4 places the combined rammer and sponge in the bucket filled with water, on the gun floor in rear of the breech, and hook withdrawing Guide Bolt handy for use.

6 and **8** go to the recesses or head of the cartridge lift and prepare to issue cartridges; for drill, they place the drill cartridges ready for use.

7 and **9** go to the shell depôts or recesses (or shell lift and shell store if supply is by the lift) and prepare shell for loading, *i.e.*, clean and fuze them. For drill, they place the drill shell and extractor in a convenient position for use. **7** hands a fuze key to **3**, who places it in a convenient position for use.

The group and battery stores are placed in their allotted position.

2 opens the breech by taking hold of the breech mechanism lever with his right hand and pulling it towards him as far as it will come. He then passes the vent bit down the vent and carefully cleans the vent, examines the breech screw and threads of the breech, sees that they are clean and free from burrs, lubricates the threads with a slight film of oil, and covers the coned seating of the obturating pad lightly with tallow. He then inserts an electric tube, pressing it past the tube retainer.

(If the pad is hard, it should be softened by immersion in hot water before firing is commenced. This is particularly important when using half-charges, should the probable temperature of the pad be below 50° F.)

The Gun Captain then sees the bore is clear.

To close the breech **2** pushes the lever home with his right hand with a continuous motion. This prepares for electric firing.

If difficulty is experienced in closing the breech, **4** will assist **2** to force the lever home, but when once the motion of closing the breech has been commenced, the lever must on no account be partially drawn back to obtain a fresh purchase, as the tube may be partially extracted, and any subsequent forward motion of the lever would bend it. In the case of a percussion tube, this might explode the detonating composition and fire the charge prematurely.

The Gun Layer tests the circuit by firing the tube, when ordered to do so by the Gun Captain.

* *To gauge the protrusion of the striker.*—Remove the lock and apply the "gauge, protrusion, striker." Ascertain by inspection that there are no small pieces of foreign metal between the point of the striker and the edge of the firing hole.

2 opens the breech, examines the pad to see if it fits properly, which he will ascertain by seeing if it is covered all over with Russian tallow, smears well with same, inserts a percussion tube, cocks the lock, and closes the breech.

3 hooks the lanyard, gives "ready," and fires the tube when ordered to do so by the Gun Captain.

2 opens the breech, thus extracting the tube, and closes it again.

(Note.—Whenever the breech is closed without inserting a tube, the extractor should be pressed well home before closing. Under no circumstances should the lock be snapped unless a tube is in the vent. Should it be necessary to ease spring, it should be done gently by hand.)

The Gun Captain collects reports from each number regarding any damage or deficiency. He then places his men under cover, and reports to the Gun Group Commander "Bore clear ready to load."

After each number has completed his work, he takes post as follows:—

Gun Captain on the right side of the rammer.

Gun Layers on the sighting steps.

2 in rear of gun in prolongation of right side of gun, left foot in front, facing auto-sight layer.

3 close up to breech on left side and facing **2**.

4 on left side of rammer.

5 to right rear of **3**.

6, 7, 8, and **9** as above detailed.

Setter according to ease of laying.

To Load.

Gun Group Commander.

Gun Captain.

"A Group.....Load."

"A 1.....Load."

2 opens breech as already detailed, and with his left hand inserts a tube, forcing it home past the tube retainer (if at percussion firing cocks the lock).

7 or **9** place projectile on gun floor. **3** picks up projectile keeping C.G. supported on his left arm and steadying base with his right hand. As breech screw swings open, he slides projectile into chamber by leaning forward, and swings round on his hips to his right to receive cartridge handed to him by **5**, who has received it from **6**. Gun Captain and **4** ram home in one motion, outer hands back up, inner hands back down and withdraw combined rammer and sponge smartly, dip it in the bucket of water, and stand by to load next round with sponge head just clear of recoil.

(Note.—When loading lyddite shell, the safety pin is withdrawn during supply from recesses by **7** or **9** before lifting shell on to gun floor. At lift supply, **3** or **5** before picking up shell removes the safety pin and uncaps the fuze. When using paper shot and powder charges, special care will be exercised in sponging out the chamber after each round, *vide* Garrison Artillery Training, Vol. I, 1910, page 173.)

3 loads cartridge and gives "In."* **2** then closes the breech with his right hand and gives "Ready." (At percussion firing, **3** or **5** hooks lanyard and gives "Ready.")

3, after loading cartridge, steps back, and **5** closes up with projectile. **3** receives cartridge from **6** and stands to right rear of **5** ready to hand cartridge to him. In this way, **3** and **5** load alternately.

Note.—At percussion firing, it is most essential that the lock be cocked *before* closing the breech, otherwise there is great danger of the tube being fired prematurely, owing to the pressure of the striker over the head of the tube.

In order to keep the mushroom head of the obturator from becoming too hot, it will be necessary to utilize every interval in the firing for cooling it by the application of thoroughly saturated cloths. Thirty rounds may be fired with the greatest rapidity without delaying the fire, but after thirty rounds a pause of about thirty seconds should be made for cooling, and if continuous rapid fire is still desired, this pause will have to be repeated about once in ten rounds.

The white metal disc of the obturator must be watched for any signs of fusion, and if the metal should begin to melt the firing ought to be suspended for thirty seconds, in order to cool the mushroom head. Firing can then be resumed, but it would be more satisfactory to change the axial vent and discs, for which about one minute is required.

TO CEASE FIRING.

On the command from the Gun Group Commander, "A. Group Cease firing," the Gun Captain gives the group letter and number of his gun, followed by the command "Cease Firing."

Electric Firing.—**2** pulls the lever towards him sufficiently to unmask the tube.

Percussion Firing.—**3** or **5** unhooks the lanyard; **2** pulls the lever towards him sufficiently to unmask the tube.

STAND FAST.

On "Stand Fast" being ordered, the tube will be unmasked, and all numbers will then stand fast and wait for the next word of command.

The gun is again made ready on the order "Action" or "Commence Firing" being given.

TO LAY.

Automatic Sight.

The gun layers adjust their deflection scales to the deflection ordered, repeating alterations.

The auto-layer sets the tide lever and error of day drum as ordered and repeats all alterations.

Rocking-bar layer lays for line and traverses.

Auto-sight layer lays for elevation and fires, and, if ordered to do so, corrects by means of the error of day drum.

* With half-charges the primed end must be towards the rear and close up to the vent. To ensure this, the cartridge should be held at the middle with the right hand palm down.

TO FIRE.

(a) *Electric Firing*.—The gun layers lay on the target and continue to follow it.

At Deliberate or Salvo Fire, they await the order or signal from the Gun Group Commander.* On receipt of this order or signal, the auto-layer will fire the gun by pressing the trigger as soon as the gun is layed.

At Independent Fire, the auto-layer fires as soon as possible after "A 1 Ready" is given.

(b) *Percussion Firing*.—Same as (a) except that **3** or **5** fires on order "Fire" from auto-layer.

CASE I.—ROCKING-BAR SIGHT.

To Lay.

The Setter will set the rocking-bar sight to the range (corrected for group difference, if any). The setter and the auto-sight layer repeat the deflection ordered by the Gun Group Commander and put it on their sights.

The rocking-bar layer lays and fires, traversing himself and giving "elevate" or "depress" to the auto-sight layer.

To Fire.

(a) *Electric Firing*.—Same as with auto-sights, except that rocking-bar layer fires by means of the pistol grip.

(b) *Percussion Firing*.—Same as with auto-sights, except that rocking-bar layer orders **3** or **5** to fire.

CASE II.

To Lay.

The rocking-bar layer and setter take post at elevation indicator and electric range dial respectively, and the auto-layer at the auto-sight. The Setter calls ranges to the rocking-bar layer, who keeps gun layed for elevation. With P.F., the Setter for training will keep the training dial reading the same as the training arc by moving the movable face.

To Fire.

(a) *Electric Fire*.—At Deliberate or Salvo Fire, they await the order or signal to fire from the Gun Group Commander. On receipt of this order or signal, the rocking-bar layer completes the operation of laying for elevation and gives "On." At this caution, the auto-layer will fire when layed for line.

At Independent Fire, the rocking-bar layer gives "On" as soon as possible after "Ready" is given.

(b) *Percussion Firing*.—Same as (a) except that **3** or **5** fires on order "Fire" from auto-sight layer.

* The Setter will, if necessary, pass the order on to the layer.

CASE III.

Auto-sight layer reads training dial and traverses. Rocking-bar layer and setter as at Case II. Auto-sight layer fires. Where a second setter is authorized, he will call out trainings to the auto layer.

After Firing.

As soon as the gun is fired, **3** or **5** unhooks the lanyard (if at percussion firing), **2** opens the breech. The gun will be at once reloaded.

Missfires.

(a) *Electric Firing.*—If when the Gun Layer presses the trigger, the gun fails to fire, he will call out "Close the Breech" and at the same time release the trigger. Gun Captain and **4** will give the breech mechanism lever a tap with the head of the rammer; Gun Captain calls "Ready." The Gun Layer will again press the trigger, and if the gun again misses fire, he will hold the trigger while he counts four in slow time, and if it fails to fire, will call "A 1 Missfire," at the same time releasing the trigger.

The Gun Layers will continue to follow the target. The Gun Captain will then order "A 1 Stand Clear," all the numbers will stand clear of the vent. The Gun Captain turns rammer end for end, inserts hook into link guide bolt and pulls it back, keeping to right rear of vent. **4** withdraws lever guide bolt with stiffened lanyard and unhooks it.

2 strikes down on the rammer with both hands, thus ejecting the tube. The Gun Captain unhooks rammer. The nearest number picks up the tube and shows it to the Gun Captain, who sees whether it has fired or not. If the tube has not fired, the Gun Captain orders "Go on," and **2** inserts a new tube, raises the lock, and keeps it up while **4** releases lever guide bolt. **2** gives "A 1 Ready."

Should there be a second missfire, the same procedure will be carried out, except that if the tube has not fired, percussion firing will be resorted to.

If the tube has fired, a pause of ten minutes will be made. All gun numbers and all cartridge cylinders will be removed to a position of safety and at the end of ten minutes, the Gun Captain will raise the lock, standing well clear, **4** releasing lever guide bolt. Gun Captain and No. **4** will then place a bucket filled with water beneath the breech of the gun. The Gun Captain then places himself clear of the breech on the left side and opens the breech by applying the rammer stave to the lever breech mechanism.

After a further pause of one minute, the Gun Captain will lean over the breech of the gun and remove the cartridge. He will then examine the igniter; if it is correct, he will use the cartridge again, adjusting it carefully in the chamber.

If the igniter is smouldering, he will drown the cartridge in the bucket of water.

Percussion Firing.—**3** or **5** will call out "A 1 Missfire."

Gun Captain and 4 will give the breech mechanism lever a tap with the head of the rammer and re-cock the lock by means of the hook on the rammer stave. 3 or 5 gives "Ready." If tube again fails to fire, it will be changed as detailed above, except that the lock will be cocked before it is lowered.

Should the second tube fail to fire, the lock will be changed.

The positions under cover are as follows :—

2, 4, Gun Captain and Setter on the right of the gun.

3, 5 and Gun Layers on left of gun.

6, 7, 8 and 9 in rear of the gun.

TO CEASE FIRING AND REPLACE STORES.

All stores are replaced by the numbers who brought them up, and the gun is left under metal by the Gun Layers ; the detachment then falls in at detachment rear.

Para. of L. of C.	Nature of Change.	Remarks.

Para. of L. of C.	Nature of Change.	Remarks.
PUBLIC LIBRARY OF VICTORIA.		

Para. of L. of C.	Nature of Change.	Remarks.

Para. of L. of C.	Nature of Change.	Remarks.

Para. of L. of C.	Nature of Change.	Remarks.
	<p data-bbox="370 1482 687 1510">PUBLIC LIBRARY OF VICTORIA</p>	